

Contents

General Information

*Columbus Clay Co. has ceramic engineers on staff to answer your questions and to provide you the technical advice you need.

*We will supply you with the best available clays, chemicals, glazes, colors and supplies at reasonable prices. We take care in preparing and packing materials for shipment.

*The variables in methods, techniques, formulations, studio practices, kilns and firing routines of schools and potters prohibit us from accepting responsibility for unsatisfactory results.

*We strongly recommend an ongoing testing routine for clays, glazes, colors, and experiments under your usual handling and firing conditions.

*Do not commit a large investment to untested materials.

Equipment Repair

Columbus Clay Company specializes in restoring Skutt, and Vulcan kilns, though we work on all major brands. If you are having problems with your kiln, give us a call. Many times we can diagnose the problem and decide on the most economical plan of correction over the phone. We stock Skutt, Vulcan and Dawson Kiln-Sitter parts for most popular models. We also repair wheels, slab rollers and other equipment.

Potters Wheel Rental

If you're thinking about trying out throwing but don't want to invest in a wheel just yet or if your'e not sure which model of potters wheel is for you, rent one of ours for a week. We have the new Shimpo VL Lite ready for you to try out. Please call for availability.

Trade-in and Sale of Previously Owned Equipment

Frequently we take equipment in trade for new kilns and potters's wheels. We recondition and offer these trade-ins for sale. Since availability is unpredictable, it is suggested that you call in periodically or better yet tell us what make and model you are looking for. We will contact you when we find it.

Columbus Clay Co. Distributors

Art Mart

409 N. Martin St.
Muncie, IN 47303
765.284.2919
artmartyr.3@aol.com

Nelsonville Emporium

31 Public Square
Nelsonville, OH 45764
740.753.1285
www.nelsonvillepottery.com

Art Supply Depo

19 S. St. Clar St.
Toledo, OH 43604
419.720.6462
www.artsupplydepo.com

Art Supply Depo BG

435 E. Wooster St.
Bowling Green, OH 43402
419.352.9501
artsupplydepo.bg.com

Clay	1-3
Slip/Modeling Materials.....	4
Plaster/Mold Materials.....	5
Bisque	6
Raw Materials	7-9
Stains/Pigments.....	10-13
Wheels.....	14-18
Equipment.....	19-22
Glazes.....	23-29
Tools.....	30-37
Kilns.....	38-45
Map	47
Index	Back Cover

1 Moist Clay Columbus Clay Company

LOW FIRE EARTHENWARE CLAYS

		Shrinkage		Absorption	
#125 White Moist Cone 06-04	A smooth, grogless, white-burning clay suited for coil work and general hand building. Unfired color is now dark gray but fires bright white.	c06	6.0%	c06	19.0%
		c04	6.5%	c04	14.5%
#127 White Sculpture Cone 06-04	This Clay is the same formula as White Moist with the addition of some fine grog. This makes the clay very suitable for larger wheel thrown and hand built pieces. Unfired color is now dark gray but fires bright white.	c06	4.5%	c06	15.5%
		c04	5.5%	c04	13.5%
#167 Red Moist Cone 06-04	A smooth, grogless, "Indian Red" color clay, suited for wheel work and general hand building.	c06	7.5%	c06	13.0%
		c04	10.0%	c04	6.0%
#177 Terra Cotta Cone 06-04	This Clay is the same formula as Red Moist with the addition of fine grog. This makes the clay a favorite for larger wheel thrown and hand built pieces.	c06	7.5%	c06	13.5%
		c04	9.0%	c04	6.5%

STONEWARE CLAYS

#146 Buff Clay Cone 2-7	Having a wide firing range, this cream colored clay is an excellent all purpose clay. A good clay to teach wheel throwing.	c2	10.0%	c2	8.5%
		c7	12.0%	c7	1.5%
#112 Brown Clay Cone 4-7	An excellent throwing clay body that contains manganese specks. Fires to a medium brown color.	c4	12.0%	c4	3.5%
		c7	13.0%	c7	1.0%
#112 NS Brown	Also available without specks.				
#124 Speckle Tan Clay Cone 4-7	Great all purpose clay body blended with fine grog and contains manganese specks.	c4	12.0%	c4	3.5%
		c7	13.0%	c7	2.0%
#130 Rustone Clay Cone 4-7	A fine grogged clay body. Fires to a deep rich brown color. Very nice for hand building or wheel throwing.	c4	12.5%	c4	1.0%
		c7	13.0%	c7	0.5%
#120 Barbs Body Cone 5-10	Very nice stoneware body. This clay throws beautifully and is great for oxidation or reduction fire. Fires to a tannish gray color.	c6	12.5%	c6	1.5%
		c10	13.0%	c10	0.5%
#129 Mather Stone Cone 6-10	A good production clay suited for making ovenware and functional dinnerware. An excellent throwing body that fires a warm gold color in reduction. Formulated by Tim Mather.	c6	11.0%	c6	6.0%
		c10	12.5%	c10	1.0%
#182 White Stoneware Cone 6-10	A very plastic throwing body, off white in color, and provides a good base for bright colored glazes.	c6	10.5%	c6	9.0%
		c10	12.0%	c10	4.0%

Columbus Clay Company

Moist Clay 2

PORCELAIN CLAYS

		Shrinkage		Absorption	
#215 Grolleg Porcelain Cone 4-7	Premium English clay body. Formulated at The Ohio State University by Jeanne Otis. Smooth and very white with excellent translucency.	c4	15.0%	c4	1.0%
		c7	15.5%	c7	0.5%
#213 Mid Range Porcelain Cone 4-7	A superior domestic porcelain body. Smooth and easy to work with. Very nice white color and plasticity.	c4	13.0%	c4	2.5%
		c7	13.5%	c7	0.5%
#217 Mather Porcelain Cone 8-10	Great smooth high fire porcelain clay. Very easy to work and is great in oxidation or reduction. Formulated by Tim Mather.	c10	14.0%	c10	0.5%

OTHER CLAYS

#116 Raku Clay White	A great raku formula that contains a blend of fine and medium grog. This body has good thermal shock resistance.	Varies	Varies
#222 "X" Clay	This clay is mill overrun clay. Great bargain clay. We cannot guarantee any firing properties. Good for non fire applications and clay therapy work.		
#202 Self Hardening Clay	This clay hardens to a relatively durable state without firing or baking. It can be decorated with acrylic or oil paints. Not suitable for functional ware.		
Dry Clays	All clays are available in dry form except for Self Hardening clay. Dry mix clays are an additional 2 cents per pound. Minimum order of 1,000 lbs		
Custom Clays	We can formulate and produce custom clay bodies in both moist and dry form. Your formula is confidential. Contact us for a quote. Minimum order of 1,000 lbs		

PRICE GUIDE

Quantity	50#	100#	500#	1000#	2000#
All clays except Grolleg Porcelain, "X" Clay, and Self Hardening Clay					
Price Per Box/ Per. lb.	\$30.00/.60 lb	\$27.00/.54 lb	\$23.00/.46 lb	\$20.00/.40 lb	\$18.00/.36 lb
# 215 Grolleg Porcelain					
Price Per Box/ Per. lb.	\$37.50/.75 lb	\$33.00/.66 lb	\$31.50/.63 lb	\$28.00/.56 lb	\$26.50/.53 lb
#222 "X" Clay					
Price Per Box/ Per. lb.	\$18.00/.36 lb	\$16.00/.32 lb	\$12.50/.25 lb	\$11.50/.23 lb	\$11.00/.22 lb
#202 Self Hardening Clay					
Price Per Box/ Per. lb.	\$75.00/1.50 lb	\$66.00/1.32 lb	Call		

Note: Please visit www.columbusclay.com for clay color charts.

Note: We have discontinued stocking Ruby Stone and Speckle Clay.

They can be special ordered. Minimum quantity is 1000 lb.

Call us toll free 1.866.410.CLAY

Serving Schools and Studios Since 1939

3 Moist Clay



		Shrinkage		Absorption	
#101 Buff Clay Cone 02-9	An all purpose stoneware clay with a wide firing range for throwing or modeling. Buff color at low temperature and soft gray at cone 9.	c4	9.0%	c4	5.0%
		c9	12.0%	c9	3.0%
#112 Brown Clay Cone 4-6	A plastic clay for wheel and modeling. The addition of granular manganese gives a speckled surface. The ideal temperature for developing best color tone is cone 5. Good results may be expected in reduction or oxidation firing.	c4	12.0%	c4	4.5%
		c6	12.5%	c6	2.5%
#153 Stoneware Clay Cone 4-10	A soft warm beige in oxidation - rich gray brown in reduction. This clay throws beautifully, has exceptional strength and versatility and responds well to all techniques.	c4	11.0%	c4	6.0%
		c10	13.0%	c10	2.0%
#181 White Stoneware Cone 6-10	A very smooth white stoneware body. Contains no fire clay. NOTE: Please add .02 lb. premium for STD 181 clay.	c6	13.0%	c6	2.8%
		c10	13.9%	c10	1.7%
#182 White Stoneware Cone 6-10	Near white plastic stoneware body. Good for use with bright glazes. Contains fire clay.	c8	11.0%	c8	3.0%
		c10	12.0%	c10	2.1%
#257 English Porcelain Cone 8-10	A porcelain body with a parian like quality. It's light and tight and transparent when thin. Contains no ball clay.	c8	13.0%	c8	1.0%
		c10	15.0%	c10	.65%
#259 Stoneware Clay Cone 4-10	Formulated to be similar to 153, but with richer color tones.	c4	12.0%	c4	4.5%
		c10	11.0%	c10	0.6%
#308 Brooklyn Red Cone 4-8	Red stoneware body with sand and grog. Oxidation firing yields red at cone 4 and deep sand at cone 8. NOTE: Please add .02 lb. premium for Brooklyn Red.	c4	12.0%	c4	2.5%
		c8	13.0%	c8	1.0%

PRICE GUIDE

Quantity	50#	100#	500#	1000#	2000#
All clays except #257 English Porcelain					
Price Per Box	\$31.50/.63 lb	\$28.50/.57 lb	\$25.50/.51 lb	\$21.00/.42 lb	\$19.00/.38 lb
# 257 English Porcelain					
Price Per Box	\$37.50/.75 lb	\$35.00/.70 lb	\$31.50/.63 lb	\$28.50/.57 lb	\$26.50/.53 lb



Laguna WC-401 B-Mix 5 Clay



B-Mix 5 offer nice characteristics. Its smooth, porcelain texture is a pleasure to throw and form, and it fires to a cream color in oxidation.
Packed in 50 lb. boxes

1 Box.....	\$31.00
2-9 Boxes..... each	\$27.00
10-19 Boxes..... each	\$24.00
20-39 Boxes..... each	\$21.00
40 & Up Boxes.. each	\$19.00

Laguna EM-217 WED Clay



This clay has been specifically formulated to be a very smooth, slow drying clay for modeling. It is used primarily by design studios and the entertainment industry for modeling, design, mock-up and tooling. Not formulated to be fired. Priced same as B mix listed above.

Note: Please visit www.columbusclay.com for clay color charts.

Columbus Clay Casting Slips

Slip/Modeling Materials 4

White Earthenware Casting Slip c 06-04

We are pleased to offer the most consistent white cone 06-04 casting slip available. Our test procedures and multi ingredient formula insure proper specific gravity, flow viscosity and quality castings every time. Packaged in 2 gallon cardboard box with heavy duty plastic bag.

All quantities \$5.00 gallon

JE-1 White Stoneware Casting Slip c 4-8

This mid range stoneware casting slip is suitable for functional as well as decorative pottery. Packaged in standard 2 gallon boxes.

All quantities \$6.50 gallon

LJ-4 White Porcelain Casting Slip c 4-6

The best all around low temperature vitreous slip available. This translucent body is a compromise between the very white, very weak bodies of some manufacturers and the yellow buff bodies of others. White in color, good green strength and trimming characteristics. Packaged in standard 2 gallon boxes.

All quantities \$10.50 gallon

NOTE: Boxed slip is for customer pickup only. For motor freight or UPS we offer any of the above slips in 3 gallon plastic pails. Cost is the price of 3 gallons of slip plus \$8.00 for the pail, plus shipping.

Sodium Silicate

A deflocculant also known as water glass, commonly used in casting slips to suspend clay particles in the least amount of water possible to attain the most dense concentration that will still flow into a plaster mold. .1-.3% recommended.. \$4.15/Pint, \$25.00/ gallon

Darvan #7

An alternative to sodium silicate to deflocculate (suspend) materials in water, recommend use .5 to 1%.....\$11.00/Pint, \$83.00/gallon

Sculpey

A white modeling compound that bakes in your home oven at 275°F to hardness in 15-20 minutes. Economical, easy handling product for the novice as well as the mature sculptor.....\$15.99 1.75 lb. box

Sculpey III Sampler Pack

Contains 30 one-ounce cubes of brightly colored modeling compound. Oven-hardens at 275°F. Excellent medium for jewelry and miniatures.....\$32.99 30 oz. box

Columbus Clay Self Hardening Clay

This clay hardens to a relatively durable state without firing or baking. Decorate with acrylic or craft paints and seal with shellac. Not suitable for functional ware. Available in red or white.....\$18.75 12.5 lb. pkg

Permoplast (Modeling Clay)

Remains soft and pliable when used over and over. Non-toxic and Sulfur free.

Cream Color.....\$5.95 1 lb. pkg

Van Aken Modeling Clay

Perfect for claymation, available in 1 and 4.5 lb. blocks, red, green, yellow, ultra blue, orange, magenta, violet, turquoise, flesh, white, black, and ivory. Remains soft and pliable, non-toxic, sulfur free.....\$4.50 1 lb. pkg, \$16.95 4.5 lb. pkg

Crea-Stone

Crea-Stone is a versatile sculpture medium which carves like soap and hardens like stone. This lightweight stone-like material is mixed with water and cast into shapes planned for sculpture, plaques, and various art forms. When aged, Crea-Stone hardens to a rough granite-like texture, lighter than stone permanent and weatherproof.....Natural or White Stone \$82.00 25 lb. pkg

Claycrete Instant-Papier Mache

All the qualities of original papier mache. No newspapers to cut-up, no flour or wheat paste, easy to prepare, easy to model, very economical and EXCEPTIONALLY WHITE.....\$9.30 1 lb. bag, \$33.95 5 lb. bag, \$99.00 20 lb. bag

Sculptamold

The best features of clay, plaster and paper mache. In dry form, this white, nontoxic compound is easily prepared by adding water, sets in 30 minutes. It adheres to almost all clean surfaces (even glass) and does not shrink so it may be applied to an armature or over any core. Very lightweight, permitting solid construction of large pieces. When dry, may be carved, sanded, sawed or even nailed. Surfaces may be decorated with water or oil base finishes.....\$8.95 3 lb. bag, \$53.95 25 lb. bag, \$102.00 50 lb. bag

Roma Plastilina

Roma is the world's finest modeling material that is permanently pliable and the choice of professional sculptors the world over. Grey-Green..... No. 2 Medium \$14.00 2 lb. block

5 Plaster/Mold Making

No. 1 Pottery Plaster USG (Plaster of Paris)

Highly uniform, noted for outstanding performance and long life. The standard of the industry. The best material for slip molds, wedging boards and plaster bats.

Moulding Plaster USG

A good utility plaster where expansion control, hardness, and strength are not of major importance. Mainly used for sculpture work.

Regular Dental Plaster

A normal set dental plaster recommended for general purpose applications, similar to Moulding Plaster.

Hydrocal White USG

A white Gypsum Cement that can be carved or added to. Good for casting and sculpting.

Ultracal 30 USG

A strong gypsum cement recommended where extreme accuracy and greater surface hardness are required. Has the lowest expansion of any rapid-setting gypsum cement available.

Hydrostone USG

One of the strongest and most durable Gypsum Cements. Especially suitable for high strength applications such as ram press dies and sculpture work.

Typical Physical Characteristics of Plasters

Type	Average Recommended Water Per 100 lbs. of Plaster	Setting Time (Minutes)	% Setting Expansion	Compression Strength (psi)
No 1 Pottery Plaster	70	27-37	0.210	2,000
Moulding Plaster	70	27-37	0.200	2,000
Regular Dental Plaster	70	19-22	0.200	2,000
Hydrocal White	45	25-35	0.390	5,000
Ultracal 30	38	25-35	0.080	6,000
Hydrostone	32	17-20	0.240	10,000

Plaster Price Per Lbs.

Type	1#	5#	10#	50#	100#	500#	1000#	2000#
No. 1 Pottery Plaster	2.75	1.65	1.05	.42	.40	.35	.33	.30
Moulding Plaster	2.75	1.65	1.05	.45	.40	.35	.33	.30
Regular Dental Plaster	2.75	1.65	1.05	.70	.48	.40	.35	.33
Hydrocal White	2.75	1.75	1.55	.85	.55	.50	.45	.40
Ultracal 30	2.75	1.75	1.55	.85	.55	.50	.45	.40
Hydrostone	2.75	1.75	1.55	.85	.55	.50	.45	.42

Mold Soap

A greasy soap specially formulated for use as a parting compound in the process of creating a plaster mold. This material should be cut with water and applied to the master form, the mold soap allows the master form to separate from the plaster once the plaster has set.

1 lbs.....\$7.75

Rubber Latex, AMACO

Make castings quickly and accurately with plaster of paris from molds made with Rubber Latex. Liquid rubber latex is applied over original models. Completed molds are tough, flexible and will often withstand 200 to 300 castings. Latex cannot be shipped in freezing weather.

Pint.....\$29.95

Gallon.....\$215.00

Mayco Molds

We are a distributors of the full line of Mayco casting and slump plaster molds. For a full selection of shapes please visit www.maycocolors.com. Call for pricing.

Custom Molds

Do you need your creation turned into a production mold? We can put you in touch with custom mold makers that can help you achieve your product. Call us for more information.

Bisque 6

Bisque Ware cone 06

We are now offering a full line of low fire bisque ware. These pieces are ready for decorating, glazing, and final firing. Great for paint your own potteries, class projects, and those who prefer the convenience of bisque. For pricing and a full selection of shapes please visit www.columbusclay.com. The Bisque listed below are items we usually have in stock. Please call for availability. If we don't have what you are looking for in stock we can get it within two days.

Item	#case	Piece/Case
MB-102	12	\$5.20/32.40
MB-104	12	\$5.20/32.40
MB-890	6	\$9.50/29.40
MB-105	12	\$4.80/28.80
MB-894	3	\$13.50/20.25
MB-115	12	\$4.80/30.00
MB-113	24	\$3.00/39.50
MB-122	12	\$5.50/33.00
MB-123	12	\$5.50/33.00
MB-1081	6	\$9.50/28.50
MB-1080	6	\$13.00/39.00

Please check our website for full line of bisque. All bisque not listed above must be ordered in case quantities.



MB 102
Coupe Dinner Plate
9.75"D

MB 104
Rimmed Dinner Plate
9.75"D

MB 890
Square Plate 11"

MB 105
Rice Bowl 5.5"D

MB 894
Funky Bowl 9.5"D

MB 115
Jumbo Mug 5"D

MB 113
12 oz Mug

MB 122
Latte Mug 6" H

MB 123
Pottery Mug 4.5" D

MB 1081
Cup and Saucer 4.5" D

MB 1080
Tea Pot 9" D

White Bisque Tiles cone 06

These industrial grade low fire bisque tiles are ready for decorating, glazing, and final firing. Perfect for wall murals, custom tiles for bathroom/ kitchen walls, and class projects.

6x6 Square Tile.....	ea. \$1.90
Case of 50 Tile.....	\$82.50
4x4 Square Tile.....	ea. \$1.25
Case of 100 Tiles.....	\$110.00

7 Raw Materials

Materials (per lb.)	1#	5#	10#	50#	100#	500#	1000#	2000#
Albany Slip (substitute)	3.30	3.05	2.75	2.35	2.20			
Alumina Hydrate	2.30	1.75	1.65	1.50	1.32	1.20		
Alumina Oxide, Calcined (100 lb bag)	3.05	2.20	1.95	1.75	1.55	1.50	1.10	
Antimony Oxide	12.10	9.90	9.35	8.80				
Balleclay (C&C)	2.20	1.40	1.05	.40	.27	.25	.23	.20
Balleclay (OM-4, KY)	2.20	1.40	1.05	.40	.27	.25	.23	.20
Balleclay (Old Hickory #1)	2.20	1.40	1.05	.40	.27	.25	.23	.20
Balleclay (TN #5/TCP-6)	2.20	1.40	1.05	.40	.27	.25	.23	.20
Balleclay (TN #10/#9)	2.20	1.40	1.05	.40	.27	.25	.23	.20
Balleclay (XX Sagger)	2.20	1.40	1.05	.40	.27	.25	.23	.20
Balleclay (Thomas)	2.20	1.40	1.05	.40	.27	.25	.23	.20
Barium Carbonate	3.30	2.75	2.50	2.20	1.65	1.50	1.35	1.10
Barium Sulfate	3.30	2.75	2.75	2.20	1.95	1.65		
Bentonite (western)	3.05	2.00	1.65	1.10	.60	.50	.45	.40
Blackbird Slip (Barnard)	2.50	1.95	1.65	1.38	1.10	1.05	.90	
Bone Ash (real)	5.50	4.95	4.40	4.15	3.60	3.30		
Borax (10 mol.)	4.40	3.85	3.60	3.05	2.75	2.20	2.10	
Boric Acid	4.15	3.30	3.60	2.75	2.50			
Burnt Umber	4.15	3.60	3.30	3.05				
Chromium Oxide	9.60	8.80	8.25	7.35				
CMC Gum (liquid)	(\$7.25/pint, \$30.00/gallon)							
Cobalt Carbonate	(\$3.30/oz, \$40.00/lb)							
Cobalt Oxide	(\$4.40/oz, \$55.00/lb)							
Copper Carbonate	9.00	8.50	8.00	7.00				
Copper Oxide (Cuperic Black)	12.10	11.00	10.45	9.00				
Copper Oxide (Cuperous Red)	12.10	11.00	10.45	9.00				
Cornwall Stone (55 lb Bag)	3.30	3.05	2.75	2.50	2.20			
Cryolite (Synthetic)	3.30	3.05	2.90	2.75	2.65			
Dolomite (Stonelite)	2.20	1.20	1.10	.70	.50	.30	.20	
Darvan #7	(\$11.00/pint, \$83.00/ gallon)							
Feldspar (G-200 EU, K) (55 lb bag)	4.00	2.50	1.90	1.50	1.20	.80	.70	.62
Feldspar (Custer 325, K)	2.20	1.40	1.90	1.05	.55	.50	.40	.35
Feldspar (Minspar, NC-4, Kona F4, Na)	2.20	1.40	1.90	.65	.40	.30	.30	.22
Fireclay (Hawthorn Bond)	2.20	1.40	1.90	.55	.45	.30	.25	.20
Fireclay (Cedar Heights)	2.20	1.40	1.90	.55	.45	.30	.25	.20
Flint (325 mesh silica)	2.50	1.95	1.40	.70	.45	.35	.30	.25
Flint (200 mesh silica)	2.50	1.95	1.40	.70	.45	.35	.30	.25
Fluorspar	2.50	2.20	1.95	1.55	1.30	1.10	1.10	.85
Foundry Hill Creme Clay	1.95	1.40	1.10	.80	.55	.30	.30	.22
Frit 3110 (leadless 200 mesh)	4.10	3.60	3.60	2.50	2.30			
Frit 3124 (leadless 200 mesh)	3.85	3.30	2.75	1.95	1.75			
Frit 3134 (leadless 200 mesh)	4.15	3.30	3.00	2.20	2.00			
Frit 3195 (leadless 200 mesh)	4.35	3.85	3.30	2.75	2.20			
Frit 3819 (FZ25/P-25)	4.70	3.85	3.30	2.50	2.20			

Raw Materials 8

Materials (per lb.)	1#	5#	10#	50#	100#	500#	1000#	2000#
Gerstley Borate (Real)	2.50	2.90	1.95	1.40	1.20	1.10	1.05	.90
Gillespie Borate (Gerstley Borate Sub)	2.20	1.95	1.60	1.40	1.10	1.05		
Goldart CH, AF Clay	2.20	1.65	1.10	.65	.35	.35	.30	.20
Gold 401 Stoneware	2.20	1.65	1.10	.65	.35	.35	.30	.20
Grog (Christy Fine Flint Clay, 35 M)	2.20	1.95	1.20	.60	.55	.46	.40	
Grog, Fine (48 M and fines)	2.20	1.95	1.20	.55	.50	.50	.45	
Grog, Medium (20-48 M)	2.20	1.95	1.20	.55	.50	.45	.40	
Grog, Coarse (12-20 M)	2.20	1.95	1.20	.55	.50	.45	.40	
Gum, Solution	(\$7.25/Pint \$30.00/Gallon)							
Iron Chromite	2.75	2.20	2.15	1.95				
Iron Oxide (Yellow)	6.35	5.75	5.25	5.00				
Iron Oxide (Black)	4.95	4.95	4.40	4.15				
Iron Oxide (Bright Red, For Glaze)	6.00	5.50	5.00	4.70				
Kaolin (Primary, Avery, Helmar)	2.20	1.95	1.65	1.10	.80	.65	.55	.45
Kaolin (EPK)	2.20	1.65	1.20	.80	.50	.40	.35	.30
Kaolin (English Grolleg) (55 lb Bag)	3.30	2.20	2.00	1.50	1.40	1.30	1.20	
Kaolin (Calcined) Glomax	3.25	2.75	2.20	1.65	1.40	1.20	1.15	
Kaolin (F.C.)	2.20	1.65	1.20	.80	.50	.40	.30	
Kaolin (#6 Tile, G.A.)	2.20	1.65	1.20	.80	.45	.35	.30	
Kiln Wash (High Fire)	2.75	2.20	1.65	1.40				
Kyanite (48 mesh) (100 lb bag)	2.75	2.20	1.45	1.30	1.00	.75		
Lithium Carbonate	7.15	6.60	6.35	5.80	5.50			
Macaloid	10.20	9.35	8.80					
Magnesium Carbonate	6.05	4.95	4.70					
Magnesium Sulfate (Epson Salts)	3.85	3.30	2.50	2.20	1.65			
Manganese Carbonate	7.45	6.90	6.35	6.05				
Manganese Dioxide Milled	3.05	2.20	1.40	1.10				
Manganese Dioxide Gran.	3.05	2.20	1.65	1.50				
Mold Soap	7.70							
Molochite (30 mesh)	3.85	2.75	2.35	1.95				
Molochite (120 mesh)	3.85	3.05	2.75	2.20				
Nepheline Syenite (A-270)	2.20	1.40	1.20	.75	.45	.35	.30	
Nepheline Syenite (A-400)	2.20	1.40	1.10	.80	.45	.40	.35	
Nickel Oxide (Black) (2.5 oz)	35.20	33.00	29.70	28.60				
Nylon Fibers	8.50	7.70	7.45	6.60	6.05	5.50		
Petalite	2.75	2.20	1.85	1.65	1.60	1.55		
Plaster (#1 Pottery, USG)	2.75	1.65	1.05	.45	.40	.35	.33	.30
Plaster (Molding Plaster, USG)	2.75	1.65	1.05	.45	.40	.35	.33	.30
Plaster (Dental USG) (100 lb Bag)	2.75	1.65	1.05	.70	.48	.40	.35	.33

9 Raw Materials

Materials (per lb.)	1#	5#	10#	50#	100#	500#	1000#	2000#
Plaster (Hydrocal White, USG)	2.75	1.75	1.55	.85	.50	.55	.45	.40
Plaster (Ultracal 30, USG)	2.75	1.75	1.55	.85	.55	.50	.45	.40
Plaster (Hydrostone, USG)	2.75	1.75	1.55	.85	.55	.50	.45	.42
Plastic Vitrox (Synthetic)	2.75	1.75	1.50	1.00	.70	.40		
Pyrophyllite (PYRAX)	2.75	1.95	1.75	1.20	.80	.50	.40	
Redart (CH, AF Clay)	2.20	1.50	1.10	.55	.40	.32	.30	.25
Red 101 Earthenware Clay	2.20	1.50	1.10	.55	.40	.32	.30	.25
Roseville Clay	2.20	1.50	1.10	.55	.40	.35	.30	
Rutile (Milled)	6.60	6.00	5.50	5.00	4.70			
Silica Flour	(Same as Flint 325)							
Silica Sand (80 Mesh Flint) (50 lb Bag)	2.20	1.50	1.10	.70	.40	.30	.25	.20
Silica Sand (30 Mesh Flint) (50 lb Bag)				.70	.40	.35	.30	.25
Soda Ash, Dense (Glass Grade)	2.75	1.95	1.55	1.10	.95	.75	.65	
Soda Ash, Light (Ceramic Grade)	2.75	1.95	1.55	1.10	.95	.75	.65	
Sodium Silicate	(\$4.15/Pint \$25.00/Gallon)							
Spodumene (AUS) (55 lb Bag)	3.00	2.15	1.85	1.45	1.10	1.05	1.00	
Strontium Carbonate	3.85	3.00	2.25	1.95	1.85			
Superpax (Zirc. Silicate)	5.25	3.00	3.30	3.00	2.75			
Talc (Texas)	2.50	1.75	1.00	.45	.40	.35	.30	.23
Tin Oxide (Opacifier) (1/4 lb \$10.00)	33.00	30.00	30.00	25.00				
Titanium Dioxide	5.50	5.00	4.40	4.15				
Ultrox (See Zircopax) (Opacifier)								
Vee Gum CER	12.10	10.95	9.60					
Vee Gum T.	11.00	9.90	8.50					
Wax Resist (Liquid)	(\$9.00/Pint \$28.00/Gallon)							
Whiting (Limestone, Calcium Carbonate)	2.20	1.75	1.10	.35	.30	.25	.25	.20
Wollastonite (Vansil W-20)	2.75	2.20	1.75	1.10	1.00	.85	.65	.55
Yellow Ochre	3.00	2.75	2.50	2.20				
Zinc Oxide (Calcined)	6.60	6.00	5.50	4.95	4.40	3.95	3.70	
Zircopax (Zirc Silicate) (Opacifier)	5.50	4.95	3.85	3.60	3.40	3.00	2.75	

Monster Clay (5 lb Block)

Monster Clay® Premium Grade Modeling Clay is a re-useable sulfur free, professional oil/wax based sculpting medium. Composed entirely of non-toxic, food grade components, Monster Clay® has an ultra smooth formulation that features a low melt temperature and a low tack feel that will not stick to tools or fingers. Monster Clay has high plasticity and has a unique elastic quality much like soft taffy when warm. At average room temperature Monster is firm enough to capture even the finest details and can be re-used and re-melted indefinitely. Monster Clay melts easily to a pourable consistency and is great for making copies of life casts where changes are needed. This sulfur free recipe is compatible with platinum silicone molding compounds. Buy it once and re-use it over and over again. Each five pound quantity of Monster Clay® Premium is individually packaged in a convenient, reusable ovenable container. Best of all Monster Clay has lower density than the average oil based clays. This means that you receive approximately 25% more clay per pound without the added cost.

\$29.95/5 lb. pkg.



Definition of a Stain

Essentially, a stain is an oxide or series of oxides and opacifiers which have been blended together, calcined (or fired), then ground to a 200 or so mesh powder. The reasons for using a stain versus an oxide, etc. are (1) **Stability of Color** — an important criteria for wall tiles, sanitary ware, etc. (2) **Insolubility** — an insoluble (in water) stain greatly diminishes the risk in handling wet glazes when dipping or pouring, etc. (3) **Color** — the fired color of most stains is identical to the raw color because it has already been fired. It is, therefore, easier to use or to mix to achieve another color. It can also be mixed with a variety of mediums to turn them into china paints, enamels, silk screen colors, decals, etc.

Key To Composition Chart

Al	Aluminum oxide	Al ₂ O ₃
B	Boric oxide	B ₂ O ₃
Ca	Calcium carbonate	CaO ₃
Co	Cobalt oxide	CoO
Cr	Chromium oxide	Cr ₂ O ₃
Fe	Iron oxide	Fe ₂ O ₃
Mn	Manganese dioxide	MnO ₂
Ni	Nickel oxide	NiO
Pb	Lead oxide	PbO
Pr	Praseodymium oxide	Pr ₆ O ₁₁
Sb	Antimony dioxide	Sb ₂ O ₃
Si	Silicon dioxide	SiO ₂
Sn	Tin dioxide	SnO ₂
Ti	Titanium dioxide	TiO ₂
V	Vanadium oxide	V ₂ O ₅
Zn	Zinc oxide	ZnO
Zr	Zirconium dioxide	ZrO ₂

Mason Stain Reference Notes

1. Can be used as body stain in porcelain at high temperatures.

1a. Use only as body stain.

Firing temperatures can only be a rough guide. Firing at 2200°F on a slow schedule may give the equivalent maturing as firing at 2300°F on a fast schedule. The cycle, atmosphere, and rate of cooling will affect the color.

2. Max. firing limit 2156°F (1180°C)

3. Max. firing limit 2390°F (1310°C)

4. Max. firing limit 1976°F (1080°C)

Zinc oxide influences the color in a glaze more than any other element. Generally, zincless glazes should contain no magnesium oxide. Some colors containing zinc are to be used in a zincless glaze. The zinc in the color is in a combined form and will not harm the color, but free zinc oxide in the glaze can destroy the color.

5. Do not use Zinc in the glaze.

6. May be used with zinc or without zinc.

7. Zinc not necessary but gives better results.

8. Best results with no zinc.

Calcium oxide content as calcium carbonate should be between 12-15% for best color development. Adding the molecular equivalent of calcium oxide with Wollastonite, a natural calcium silicate, often gives better uniformity. The increased silica from the Wollastonite must be subtracted or the glaze will have a poor surface.

9. Glaze must contain 6.7 to 8.4% Calcium Oxide.

Notes by Mason Stain Company — You must test under your conditions.

High Fire Red, Yellow, Orange Stains

If you make your own glazes this is the way to go. These stains can be used as a glaze or body stain and have been tested stable up to cone 10. Non toxic and food safe when used in a non toxic and food safe glaze formula.

#4170 Fire Engine Red

#4210 Bright Orange

#4250 Bright Yellow

Price: \$16.00 for 1/4 lb., \$50.00 for 1 lb.

Call for larger quantities.

Ceramic Stain Sale

We have a large supply of assorted ceramic stains. They have been manufactured by Ferro, Degussa, General Color, Pemco, O. Hommel and others. Here is the deal. You will get from 3/4 to 1 lb. of stain per jar. For this deal you can NOT pick specific colors or ask us to match Mason or any other color manufacturer stain. We do not do ANY testing of these colors. They are sorted into color groups. You can ask for assorted colors, or ask for BLACK, BLUE, YELLOW, GREEN, BROWN, GRAY, PINK, or MAROON. Some other colors are available. The value of these stains are from \$7 to \$25 per pound, so this is a GREAT DEAL! Please do a test before using any stain in your production. Contact us if you have any questions. You can save a lot of money with this stain promotion.

\$4.00 each (3/4-1 lb.)

SPECIAL get 12 for \$40.00

This is a value of over \$150!

11 Stains

Number and Color		Composition	1/4#	1#	5#	Reference
6000	Shell Pink	CrSn	\$6.75	\$22.00	\$96.00	3,5,9
6001	Alpine Rose	CrSn	6.75	22.00	96.00	3,5,9
6002	Rose Rose	CrSn	6.75	22.00	96.00	3,5,9
6003	Crimson	CrSn	6.75	22.00	96.00	3,5,9
6004	Crimson	CrSn	6.75	22.00	96.00	3,5,9
6005	Deep Crimson	CrSn	6.75	22.00	96.00	3,5,9
6006	Deep Crimson	CrSn	6.75	22.00	96.00	3,5,9
6007	Peach	CrSnV	7.25	24.00	102.00	3,5,9
6008	Peach	CrSnV	7.25	23.00	100.00	3,5,9
6009	Coral	CrSnV	7.50	22.00	93.00	3,5,9
6020	Pink	MnAl	6.25	17.00	71.00	1,3
6023	Clover Pink	ZrVCrSn	6.25	21.00	87.00	3,5
6029	Persimmon	CrAlFeZn	5.00	15.00	61.00	3,8
6031	Deep Salmon	CrSnFe	6.75	22.00	87.00	3
6032	Coral	FeZr	5.75	19.00	75.00	3
6052	Doll Flesh	CrMnAl	5.25	17.00	71.00	1,3,6
6067	Pink Extender	Sn	6.75	12.00	85.00	3,5
6090	Coral	CrSnV	7.75	24.00	100.00	3,5,9
6098	Flesh	CrSnVZr	6.75	19.00	81.00	3,5,9
6100	Woodland	CrFeZnAlSi	5.75	16.00	66.00	3,6,7
6101	Chestnut	CrFeZnMn	5.75	15.00	63.00	3,6,7
6103	Golden	CrFeZnAl	5.75	16.00	65.00	3,6,7
6104	Fawn	ZrVCrSn	6.75	22.00	98.00	3,6,7
6107	Dk. Golden	CrFeZnAl	5.75	16.00	65.00	3,6,7
6108	Walnut	CrFeZnMn	5.75	17.00	71.00	3,6,7
6109	Deep Brown	CrFeZnAl	5.00	16.00	65.00	3,6,7
6111	Spice Brown	FeSnZn	6.75	21.00	81.00	3,6,7
6113	Claret	CrFeZn	5.00	15.00	55.00	3,6,7
6119	Russet	CrFeZnCaZr	4.75	15.00	60.00	3,6,7
6121	Saturn Orange	CrFeZnAl	5.75	16.00	65.00	3,6,7
6124	Chocolate	CrFeZnAlMn	5.75	17.00	70.00	3,6,7
6126	Hazelnut	CrFeZnAl	5.75	17.00	70.00	3,7
6129	Golden Ambrosia	CrFeZnAl	5.75	16.00	65.00	3,6,7
6131	Titanium Iron	TiFe	5.75	16.00	65.00	1a,3,6
6149	Iron Silicate	FeSi	5.00	15.00	60.00	3,6,7
6153	Seal Brn.	CrFeZnMn	5.00	15.00	55.00	3,6,7
6160	Dark Chocolate	CrFeZnAl	5.00	14.00	58.00	3,6,7
6163	Terra Cotta	CrFeZnAl	5.75	16.00	65.00	3,6,7
6190	Deep Brn.	CrMn	5.00	15.00	55.00	3,6,7
6194	Manganese Sillicate	MnSi	5.00	15.00	55.00	3,6,7
6200	Evergreen	CrCoSi	5.75	17.00	71.00	3,5

See page 10 for reference notes and composition key.

NOTE: We have many additional stains from other manufacturers. Please call for specific information.

Stains 12

Number and Color		Composition	1/4#	1#	5#	Reference
6201	Celadon	CrCoZnAlSi	\$5.75	\$16.00	\$68.00	1,3,6,8
6202	Florentine	CrCoSi	6.75	20.00	85.00	1,3,6,8
6204	Victoria Green	CrCaSiZr	5.75	17.00	68.00	3,5,9
6206	Grass Green	CrCa	5.00	15.00	60.00	3,5,9
6207	Celeste	CrCoZnAl	5.75	17.00	68.00	3,6
6209	Chrome	CrSi	6.75	21.00	89.00	3,5
6211	Pea	ZrVSn	7.75	24.00	106.00	1,3,6,8
6219	French	CrCoZnCaSi	5.75	17.00	70.00	1,3,5,8
6221	Turquoise	CrCoZnCaZr	5.00	15.00	60.00	3,5
6223	Ivy	CrAlSi	5.75	18.00	75.00	3,5
6224	Dk. Green	CrCoZnSiFe	5.75	16.00	67.00	3,5
6226	Dk. Leaf	CrCoZnSiFe	5.75	15.00	63.00	1,3,6,8
6236	Chartreuse	ZrVSn	7.75	26.00	116.00	1,3,6,8
6242	Bermuda	ZrVPr	5.75	16.00	68.00	3,6
6246	Blue Green	CrCoZnSn	6.75	29.00	86.00	3,6,8
6254	Dk. Teal Green	CoCrAlSiZn	7.75	24.00	100.00	1,3,6,8
6255	Jade Green	CoCrAlSiZn	7.75	27.00	106.00	1,3,6,8
6264	Victoria	CaCrSi	5.75	16.00	67.00	3,5,9
6265	Leaf Green	CrCoZnCaSi	5.75	17.00	70.00	3,5,9
6266	Peacock	CrCo	10.00	33.00	146.00	1,3,6,8
6268	Sea Green	CrCoZnSi	6.75	21.00	90.00	1,3,6,8
6271	Mint Green	CrCoZnCaSi	5.75	17.00	68.00	3,5,9
6274	Nickel Silicate	NiSi	6.75	22.00	96.00	1,3
6280	Avocado	ZrVCrFeCo	7.75	23.00	95.00	3,6
6288	Turquoise	ZrVCrCa	5.75	16.00	66.00	3,5,9
6300	Mazerine	CoSiZn	10.00	35.00	147.00	1,3,6
6302	Cadet	CrCoAlSiSn	8.00	24.00	101.00	1,3,6
6303	Deep Orchid	CrSnCo	8.00	24.00	101.00	3,5,9
6305	Teal	CrCoAlSiZn	8.00	23.00	96.00	1,3,6
6306	Vivid	CoAlSiZn	7.00	23.00	96.00	1,3,6
6307	Pastel	CoAlSiZrSn	6.00	16.00	66.00	1,3,6
6308	Delphinium	CoAlSn	7.75	24.00	101.00	1,3,6
6310	Wedgewood	CoAlSi	9.00	30.00	131.00	1,3,6
6313	Medium	CoZnSi	9.00	29.00	121.00	1,3,6
6315	Deep Turquoise	ZrV	5.75	18.00	76.00	1,3,6
6319	Lavender	MnAlCo	7.75	24.00	103.00	1,3
6320	Delft	CoAlSiSn	11.00	35.00	116.00	1,3,6
6331	Orchid	CrSnCo	8.00	24.00	96.00	3,5,9
6332	Orchid	CrSnCo	8.00	24.00	96.00	3,5,9
6333	Lavender	CrSnCo	7.00	23.00	91.00	3,5,9
6336	Peacock	CrCoAlSiSn	9.00	29.00	116.00	3,6
6339	Royal Blue	CoAlZn	8.00	27.00	111.00	1,3,6
6343	Mediterranean	CrCoAlSiZn	8.00	25.00	106.00	1,3,6
6360	Blue Willow	CoAlSi	9.00	26.00	111.00	3,5
6363	Sky Blue	CoAlSi	5.75	16.00	62.00	1,3,6

See page 10 for reference notes and composition key.

NOTE: We have many additional stains from other manufacturers. Please call for specific information.

13 Stains

Number and Color		Composition	1/4#	1#	5#	Reference
6364	Turquoise	ZrV	\$5.75	\$18.00	\$71.00	1,3,6
6368	Copenhagen Blue	CoZnAlSi	7.00	21.00	86.00	1,3,6
6371	Dark Teal	CrCoAl	5.75	31.00	131.00	1,3,6
6373	Turquoise Blue	ZrVCrCoSn	5.75	19.00	75.00	3,6
6376	Robins Egg	ZrV	5.75	16.00	65.00	1,3,6
6381	Blackberry Wine	CrZnCo	8.00	24.00	106.00	3,5,9
6383	Cobalt Aluminate	CoAl	12.50	37.00	166.00	1,3,6
6385	Pansy Purple	CrSnCo	8.00	24.00	101.00	3,5,9
6387	Mulberry	CrSnCo	12.50	37.00	141.00	3,5,9
6386	Navy Blue	CoCrFeNiSiZn	8.00	24.00	106.00	1,3,6
6388	Mazerine	CoSi	13.00	35.00	151.00	1,3,6
6389	Sapphire Blue	CoAl	13.00	35.00	151.00	1,3,6
6392	Dusty Lavender	CrSnZrV	6.75	19.00	81.00	3,5,9
6393	Turquoise Blue	ZrVCoSn	6.75	19.00	81.00	3,6
6396	Peacock	ZrVCrCoAl	6.00	19.00	81.00	1,3,6
6404	Vanadium	SnV	9.00	27.00	116.00	1,3,6
6405	Naples (6400)	FePrSiZr	5.75	14.00	51.00	3,6
6406	Buttercup (6401)	FePrSiZr	6.75	16.00	71.00	3,6
6407	Marigold	ZeFePr	5.75	15.00	61.00	3,6
6450	Praseodymium	PrZrSi	5.75	18.00	71.00	3,6
6464	Zirconium	ZrV	8.00	25.00	101.00	1,3,6
6471	Old Gold	SnVCrFeZn	8.00	23.00	92.00	1,3,6
6485	Titanium	CrTiSb	5.75	18.00	71.00	1a,3
6500	Sage Green	CrCoNiSi	7.00	21.00	86.00	1,3,6
6503	Taupe	CrFeAlSiZr	5.75	16.00	59.00	3,5,9
6506	Pearl	CrFeCoNiSn	8.00	22.00	93.00	3,6
6527	Shadow	CrFeAlSiSn	6.00	17.00	60.00	3,5,9
6528	Charcoal	CrFeCoSnNi	9.00	27.00	116.00	3,6
6530	Silver	CrFeCoNiSn	9.00	28.00	116.00	3,6
6537	Mouse Grey	CrAlFeSiSnZr	5.75	16.00	66.00	3,5
6540	Blue Grey	CrFeCoNiSn	9.00	29.00	121.00	3,6
6572	Neutral	CrFeZr	5.75	14.00	60.00	3,5
6573	Rose Taupe	ZrVCrSn	6.75	19.00	77.00	3,5,9
6600	Black	CrFeCoNi	8.00	24.00	106.00	1,3,6
6601	Velvet	CrFeCoNiZn	11.00	28.00	116.00	1,3,6
6612	Onyx	CoCrFeNi	11.00	33.00	141.00	1,3,6
6616	Black/Chrome Free	CoFeMn	10.00	33.00	136.00	1,3,6
6650	Black/Cobalt Free	CrF	6.75	18.00	72.00	3,5
6657	Black	CrFeCo	6.75	18.00	72.00	3,5
6666	Black/Cobalt Free	CrFeMn	6.00	19.00	77.00	3,5
6700	White	ZrAlSi	6.00	15.00	61.00	3,6
6768	Tin White	SnAlSi	10.50	33.00	141.00	3,6,8

See page 10 for reference notes and composition key.

NOTE: We have many additional stains from other manufacturers. Please call for specific information.



Electronic speed controls, permanent magnet DC motors and all steel construction are used in our variable speed power wheels (B, C, CXC, and EX). Our foot pedal is the smoothest in the industry, with speed range from 0 to 240 rpm and exceptional power. All wheels are equipped with automatic belt tensioning and belt guards. The steel tables for B, C and CXC are welded from 1/4" steel plate for weight and rigidity; the EX uses 5/16" steel plate. Models B, C, CXC and EX feature modular control for reversing wheel direction and easy repair or replacement of foot pedal and motor. Also available in 220 volt. Most Brent wheels come with a TEN YEAR WARRANTY

MODEL EX

The EX is the most powerful Brent® wheel ever! The heavy-duty 1-1/2 hp, 15 amp motor has the power to center over 450 lbs. of clay. Together with the 5/16" steel table, the EX can handle virtually any throwing project. The EX is driven by an 6-groove poly-v belt for the best combination of power and efficiency.

Includes FREE Splash Pan and 14" Plasti-bat®!
Model EX Wheel with Splash Pan.....\$1795.00

MODEL CXC

For years the CXC has been our heavy-duty wheel for the potter requiring strong, consistent performance. It still features all-steel construction, a tough 1 hp motor, 14" head, solid 1/4" steel table and the smoothest 0-240 rpm foot pedal available. The 6-groove poly-v drive belt provides the best combination of power and efficiency. The Brent® CXC wheel can center up to 300 lbs. of clay. Includes FREE Splash Pan and 14" Plasti-bat®!

Model CXC Wheel\$1695.00

MODEL C

The standard no one can match. It centers 225 pounds with a 3/4 hp motor and has a reputation for mechanical efficiency, long life and quiet, vibration-free dependability. The 14" aluminum head runs on permanently sealed double row ball bearings. Includes FREE Splash Pan and 14" Plasti-bat®!

Model C Wheel\$1595.00

MODEL B

Designed to fill the needs of school and studio potters. Competitively priced, this wheel is quiet and solid under loads of 150 pounds of clay. The B has the table and drive system of the C, combined with a 1/2 hp motor for the power and weight necessary for school use. Includes FREE Splash Pan and 12" Plasti-bat®!

Model B Wheel with Splash Pan....\$1495.00

Call us toll free 1.866.410.CLAY



MODEL ie

The Brent® model ie wheel is economical, well-built, and has many features of the larger Brent® wheels. It has a sturdy 3/16" angle iron frame, recycled high density poly top, and the 1/4 hp motor can handle up to 75 lbs. of clay. The ie has removable legs making it very portable for taking to workshops and demonstrations and can be shipped by UPS.

Model ie Wheel\$1095.00



MODEL ie-x

The ie-x has all of the features of the ie (above) with the following enhancements: 1/3 hp motor that can handle 100 lbs. of clay, reversing switch, 14" cast aluminium wheel head, FREE 14" Plasti-bat®, and FREE splash pan. Includes FREE Splash Pan and 14" Plasti-bat®!

Model ie-x wheel\$1250.00

**Most Brent Electric Potters
Wheels Come With A 10 Year
Warranty!**



SEAT (as shown on model B)

This sturdy seat attaches directly to Brent® B, C, CXC, and EX wheels. The seat height is adjustable from 19" to 25-1/2" for maximum comfort while throwing. Seat and wheel sold separately.

Seat\$299.00



LEG EXTENSION KIT

Raise your wheel to standing height to reduce stress on your back. This leg extension kit fits wheels B, C, CXC, and EX and adjusts the head height from 31-1/2" up to 42" high.

Leg Extension Kit\$249.00



BRENT® BOOTIES

Potters wheel risers, designed for tall potters who throw sitting down. The Brent® Booties are packaged in sets of three and are designed to fit the Brent® EX, CXC, C, and B potters wheels. Brent® Booties are reversible, allowing you to raise your wheel 2 or 4 inches depending on your need.

Brent® Booties (set of 3).....\$39.00

Serving Schools and Studios Since 1939

15 Potters Wheels

Brent Curved WorkStation Brent WorkTables

Add versatility and convenience to your Brent B, C, CXC or EX wheel with these accessories. Store Clay, modeling tools, brushes and other supplies on the surface or in cup holders to keep them within arm's reach. The Brent WorkStation and WorkTables are 1/3" thick and are made from the same rigid easy to clean material as the AMACO Plast-i-bat and adapt-A-Bat. Both are supplied with steel supports and adjustment/tightening knobs that attach to the two rear legs of the Brent wheel. The Curved WorkStation can be used in conjunction with the WorkTables for maximum convenience.



WorkStation

This one piece table measures 35 1/4" wide by 18 deep and attaches to the wheel legs with four steel supports (two per side). It also has two storage cup holders. The height of the table can be adjusted by using one or both knobs on each side at the same time. Loosen the front knobs, the side knobs (or all four), raise or lower the table to the desired height then tighten to secure.

Brent Curved WorkStation.....\$275.00



WorkTables

These two tables attach to the wheel legs with the same supports and knobs as the Curved WorkStation except they can be independently adjusted. One table is 16" by 10" and the other is 18" by 10" with a cup holder. Both tables are fully adjustable.

WorkTable Set.....\$275.00

16" by 10" WorkTable.....\$149.00

18" by 10" WorkTable.....\$140.00

Serving Schools and Studios Since 1939

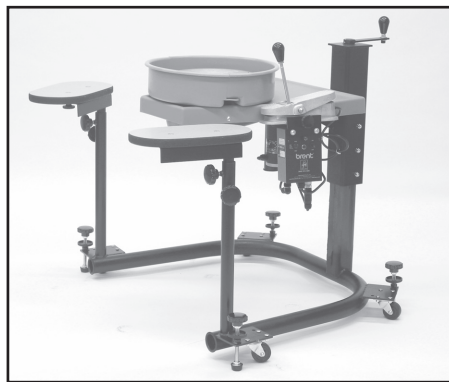

AMACO® Rehabilitation Potter's Wheel No. 16

Designed in coordination with leading rehabilitation and therapy experts, the No. 16 wheel is totally adaptable! It features sturdy construction that adjusts to fit any situation. With a powerful 1/3 HP motor that is reversible, variable speeds from, 0-200 rpm., a cast aluminum head, and a non-breakable splash pan, the No. 16 wheel works in situations where a conventional wheel will not.

Overall dimensions are 47-3/4" wide and 32" deep. Full ten year limited warranty.

AMACO® Rehabilitation Potter's Wheel No. 16 with standard throwing head and bat pins.....\$2995.00

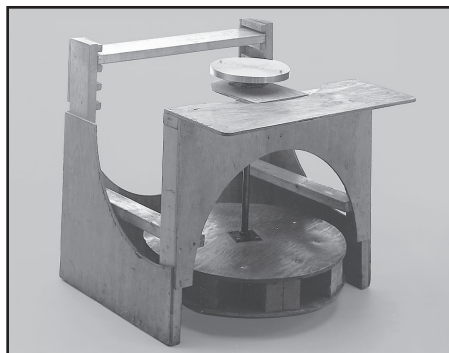

Kick Wheel Wood Kit

The Kick Wheel Wood Kit, together with the separate metal parts kit, contains everything you need to build your own kick wheel. This kit contains all the wood pieces, pre-cut and ready for assembly. The unique frame design uses a 1/2" exterior plywood stressed skin, which is as rigid as most steel designs. To complete the wheel, all you will need is a drill, hammer, nails, glue, and bricks.

The metal parts kit includes a 12" or 14" aluminum head, high quality cast iron mounted ball bearings, flywheel flanges, nuts and bolts, and illustrated instructions.

Kick Wheel Wood Kit\$265.00

Metal Parts Kit 14" Wheel Head....\$310.00



MODEL EJ

The Brent® Model EJ wheel functions as both a kick wheel or power driven wheel. It has all the quality features of the J wheel with the addition of a 1/3 hp motor.

Model EJ Wheel..... \$2695.00

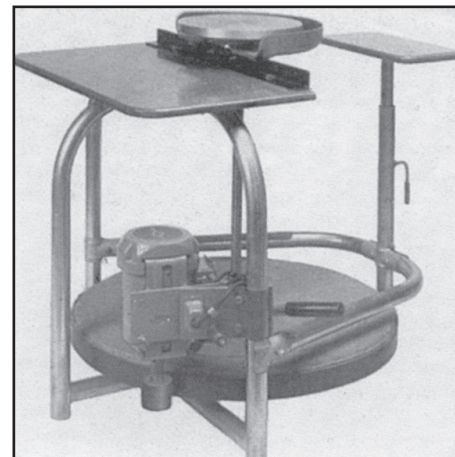

Shown with OPTIONAL MOTOR

Thomas Stuart Kick Wheel

Thomas Stuart kick wheels are efficiently designed to provide maximum performance and durability. Since 1970, they have been built to the highest standards of quality, meeting the most stringent demands of professional and amateur potters alike.

The frame is formed entirely of rigid steel pipe, which is galvanized to be rust proof. The bolt together construction eliminates the common problems of tight corners and stairways. The frame's unique design has a 4 point stance, which offers stability unmatched on the market today.

The 140 lb. flywheel is accurately cast with a full two inches of concrete. This, combined with the true balancing of every flywheel, gives you a precision wheel at a reasonable price. The flywheel turns a standard 12" cast aluminum wheel head.

The motor attachment has a 1/3 horsepower motor, which is totally enclosed to prevent dust from damaging its internal components. The drive system features a rubber drive wheel, which contacts the edge of the concrete flywheel. The motor attachment can be added to the wheel at any time, without modification.

Specifications: Floor Space 34"x37"

Height 31" – Weight Assembled 200 lbs.

Unassembled

Kick Wheel CALL FOR PRICE

Assembled

Kick Wheel CALL FOR PRICE

Splash Pan CALL FOR PRICE

Motor Option CALL FOR PRICE

Visit our website at www.columbusclay.com

SHIMPO

Potters Wheels 16

RK-Whisper

The latest in Shimpo's line of superior products, the RK-Whisper is the next generation of potters wheels. Not just quiet, but QUIET! This wheel is by far the quietest on the market; you can actually throw and hear yourself think at the same time. This wheel features a brushless DC motor and direct drive system (NO BELTS or CONES). The motor is an electronically controlled series of electro magnets. It is operated by a fixed foot pedal with a hand lever. The steel body is durable under all conditions. Five year warranty.

Model RK-Whisper Specifications

Motor: 1/2 HP, 400 W, AC 115V, 60 Hz
Drive System: Direct Drive DC Brushless Motor
Speed Control: Fixed Foot Pedal w/ Hand Lever
Wheelhead Speed: 0-250 rpm
Wheelhead Direction: Clockwise/Counter-Clockwise
Centering: 100 lbs.
Wheelhead: 12 inch light alloy casting, drilled for bat pins
Dimension: 20 x 21 x 20"
Ship Weight: 135 lbs.
Price \$1205.00



VELOCITY VL-Whisper

The superior technology of Shimpo's RK-Whisper potter's wheel and the popular features of Shimpo's Velocity V75 potter's wheel have been combined to create the second model in Shimpo's Whisper series potter's wheels, the VL-Whisper. Responsive, high torque at all speeds, powerful and we can now say the quietest wheel in the potter's wheel market. Five year warranty and two piece splashpan included

Model Velocity VL-Whisper Specifications

Motor: 1/2 HP, 400 W, AC 115V, 60 Hz
Drive System: Direct Drive DC Brushless Motor
Speed Control: Remote Foot Pedal
Wheelhead Speed: 0-250 rpm
Wheelhead Direction: Clockwise/Counter-Clockwise
Centering: 100 lbs.
Wheelhead: 14 inch light alloy casting, drilled for bat pins
Dimension: 23 1/8 x 27 1/2 x 22 3/4"
Ship Weight: 135 lbs.
Price \$1315.00



VL-Lite

Designed with the potter in mind, the VL-Lite is a belt-driven lightweight wheel. "Lite" enough to carry yet sturdy enough to throw on. Featuring a remote pedal, two-piece splashpan, workspace, 100-watt reversible motor, an automatic belt-tensioning system and a "Lite" price. Five year warranty.

Model VL-Lite Specifications

Mtor: 1/2 hp, 100W DC
Speed Control: Remote Foot Pedal
Wheelhead Speed: 0-250 rpm
Wheelhead Direction: Clockwise/Counter-Clockwise
Centering: 25 lbs.
Wheelhead: 12" Alloy with Bat-Pins
Dimension: 22" x 28" x 21"
Wheel Weight: 51 lbs
Ship Weight: 84 lbs
Price \$732.00



SHIMPO ACCESSORIES

Splash Pans.....(call for more information).....\$45.00-\$88.00
Wheel Leg extension kit VL-Whisper.....\$185.00

17 Potters Wheels

Shimpo Slab Roller

Heavy-duty slab roller can produce up to a 3" thick slab. Two-roller system evenly distributes pressure on slab to reduce warping. Dual hand wheels and thickness indicator provide synchronized fine adjustment and allow for precise control of slab thickness. Wagon wheel handle provides effortless feeding of slab through rollers in either direction. Large 30" x 50" table. Comes with one canvas set. **Price \$895.00**

SPECIAL: Free Shipping on the Shimpo Slab Roller. Give us the order and we will arrange the free delivery.



Shimpo Mini Slab Roller

Produces thicknesses up to 1". Weighs only 31 lbs. and had a compact design that makes it easily portable. 16" x 24" Table. **Price \$560.00**

Shimpo Wonder Bats

- 12" Bat.....\$12.00
- 14" Bat.....\$13.25
- Wonder Bat Package\$35.75
(Master Bat with six inserts)



Shimpo Handheld Extruder
\$49.95

Shimpo Hollow Die Set
\$35.00



Shimpo Potters Stool
\$59.95

Potters Wheels 18

Speedball Bats

Easy lift rim makes removing the bat from the wheel head simple in one easy motion that won't disturb your pot. These injection, molded plastic bats are long lasting-maintaining their shape and size. Speedball bats fit all wheel bat pin hole spacing. 7.5" square bats save room on your shelf so you can store more pots. Unique Speedball bat ribs add strength and durability.

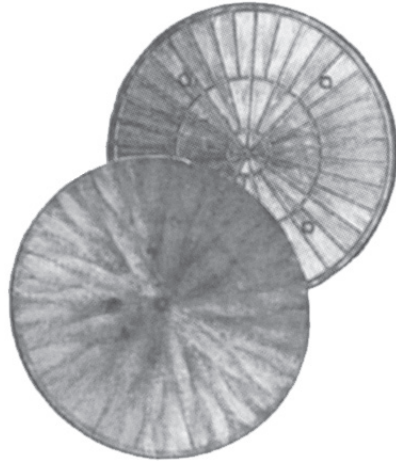

- 7-1/2" Speedball Square Bat \$6.00
- 12" Speedball Round Bat \$9.00
- 14" Round Bat \$10.00

Creative Industries Sanding Discs

Great for pot bottom grinding, attaches to wheel head.

- 50 Grit \$12.49
- 80 Grit \$12.49

Bat Pins

Fits Brent, Amaco, Shimpo, Creative Industries, and Thomas-Stuart wheels.....\$3.25

Splash Pan

A high density polyethylene molded yellow pan which fits all Brent® wheels. This pan is designed to catch excess water and protect the bearings. It snaps under the top bearing housing, with no bolts, screws or pins to get lost. Easily removed for cleaning.

Splash Pan.....\$49.95



Giffin Grip

A re-centering and holding tool for leather-hard or bisque ware. Designed specifically for trimming, it works equally well with waxing the foot or banding with underglazes or engobes. Three arms gently corral your pot into the center. After an initial one-time adjustment, the Giffin Grip simply snaps on and off your wheel. Includes Giffin Grip, basic and wide slider sets, 2", 4", and 6" arms. Giffin Grip.....\$199.95

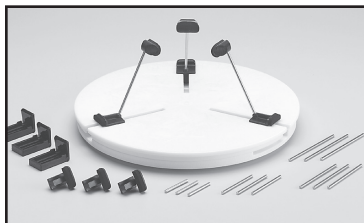

Plasti-Bat

Plasti-Bat® was designed by studio potters to be a versatile, long-lasting, high-quality bat that is virtually indestructible! Made of 1/4" -3/8" thick, very rigid, high impact plastic, they will provide continuous use, will not splinter, delaminate, swell or shrink. They are easy to clean and are impervious to water and most chemicals.

Plasti-bats drilled with bat pin holes have one oblong hole for a better fit on your AMACO® or Brent® wheel. The holes will remain just as drilled and will not become oversized with use. The surface is a non-absorbent, positive adherence surface that does not allow clay to slide or turn loose while centering. Plasti-bats are lightweight, easy to stack, carry and store. Pots removed from a Plasti-bat® have a totally smooth, clean surface. NOTE: 8" and 10" Plasti-bat® will always be drilled 6" apart to fit Adapt-A-Bat®

Description	Distance	Pins	Price
8" Drilled	6"	2	\$9.95
10" Drilled	6"	2	\$11.95
12" Drilled	10"	2	\$15.45
14" Drilled	10"	2	\$18.95
16" Drilled	10"	2	\$29.95
18" Drilled	10"	2	\$39.95
20" Drilled	10"	2	\$45.95
9x9 Square	10"	2	\$9.95

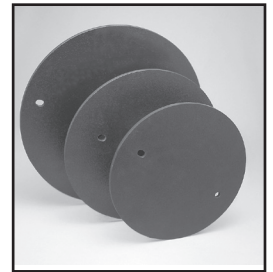

Adapt-A-Bat

The Adapt-A-Bat™ from AMACO® allows the use of 8" and 10" bats on larger wheel heads that are not drilled to accept smaller size bats with holes 6" apart on center. There are two versions available: 1) pre-drilled with holes 10" apart on center or 2) without bat pin holes. Both versions include two bat pins that are 6" apart on center to allow the use of smaller bats.

Adapt-A-Bat™ is available individually or as a set that includes the 14" Adapt-A-Bat™ plus two 8" and two 10" Plasti-Bat® either with pre-drilled bat pin holes or without. One Adapt-A-Bat™, together with several 8" or 10" Plasti-Bats is the perfect solution for high volume production or classroom instruction when smaller objects are being thrown and several students are sharing the wheels.

Adapt-A-Bats are constructed from specially formulated, 1/4" thick tough plastic for strength and long life. They won't swell or shrink, are easy to clean and are impervious to water and most chemicals.

- Adapt-A-Bat™ with bat pin holes.....\$36.95
- Adapt-A-Bat™ without bat pin holes.....\$30.00
- Adapt-A-Bat™ plus 2- 8" & 2 -10" Plasti-Bat® with bat pin holes.....\$72.00
- Adapt-A-Bat™ plus 2- 8" & 2 -10" Plasti-Bat® without bat pin holes.....\$68.00

Pressboard Bats

Made of 3/4" durable pressboard, 14" or 22" in diameter, fits 10" bat pin spacing. Shipping weights, 3 and 4 lbs.

Description	Price
14" Bat.....	\$14.95
22" Bat.....	\$20.95



19 Equipment



AMACO Potter's Stool

Made from heavy gauge tubular steel with a durable enamel finish. It stands 18" high and can be used with all wheels.

Stool..... \$81.00



Potter's Stool ST 5

Has thin, firm, durable cushion. Manual adjust spindle, 5 leg base for stability.

ST 5.....\$109.00



Potter's Stool ST 4

Rugged and contoured seat provides lower back seat support. Made from molded plastic and a firm cushion, durable in the most severe-use conditions. Easy to clean. Air cylinder finger touch height adjustment extends from 16"-23". Five leg base with glides for stability.

ST 4.....\$119.00



Brent Ware Cart EX

Designed for stability, convenience and versatility. Stability is achieved by a one-piece construction per side using a single bent 1" heavy walled steel pipe with welded-on shelf supports. Heavy duty Kee clamps are used to connect the sides with three, 1" diameter steel pipes. The ware cart, standing 77" tall, 24" deep and 32" wide, is on swivel casters with 4" rubber tires to give you the convenience of rolling the cart from place to place. Cart is shipped knocked down and can easily be assembled.

Optional shelves (12) are made from 1/2" exterior grade plywood.

Ware Cart with cover..... \$589.00

Ware Cart Shelves (12) 125.00



Brent Kiln Shelf Cart

A mobile, efficient means of loading and unloading your kiln, the Kiln Shelf Cart is 47" high, 35" long and 13" wide. Steel rods keep up to 16 kiln shelves (up to 20" high) stored vertically and separated for less damage. Three shelves give you room for stacking posts, cones, stilts, pots, etc. and are interchangeable with the ware cart shelves.

Kiln Shelf Cart \$625.00



Brent Bat Mobile

A great way to store your unused bats. The Batmobile can hold 60-90 bats, depending on thickness and has an adjustable shelf to accommodate 12" to 14" bats. Standing 42" x 35" x 14", the Batmobile's top shelf can also be used on the ware cart.

Batmobile \$479.00

Equipment 20

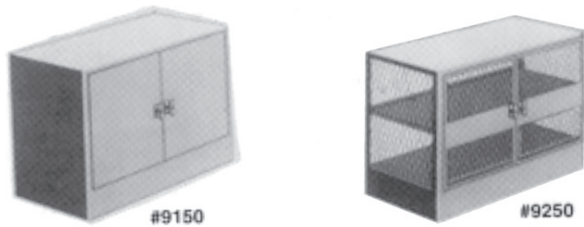

CERAMIC CABINETS are designed and engineered specifically to the requirements of the functional ceramic work areas. They offer exceptional quality, security and service.

Features:

- cabinets of heavy gauge, welded steel construction, shipped set-up ready for use.
- furnished with two heavy duty hinged doors to allow full use of shelves.
- doors have "overlap" construction with positive 3-point locking mechanism; satin chrome locking handles with 2 keys.
- metal surface cleaned and bonderized before painting.

Small Damp Cabinet-Base Type ... Model #9150

Offers the same construction features as above. Furnished with two shelves, each having one highly absorbent bonded foam bat. 36"W x 19"D x 31"H. Dark Brown/Antique Gold doors. Shpg. wt. 125 lbs.**CALL FOR PRICE**

Small Drying Cabinet-Base Type ... Model #9250

Offers the same construction features as above. This unit is furnished with 2 large angle-frame shelves covered with 1/8" tempered pegboard. Cabinet size 36"W x 19"D x 31"H. Dark Brown/Antique Gold doors. Shpg. wt. 125 lbs.**CALL FOR PRICE**

Portable Clay Storage Cart ... Model #9405

Ideal for bulk clay storage, keeping clay moist and workable, with the added feature of mobility. This new heavy duty, all steel constructed cart, with removable plastic clay container and lid, accommodates approximately 140# of clay. Cabinet has hinged lid for easy access. 4" ball-bearing swivel wheels for easy mobility. Overall cabinet size 17-1/2"W x 13-1/2"D x 28-1/2"H. Dark Brown/Antique Gold doors. Shpg. wt. 31 lbs. (Can ship UPS).....**CALL FOR PRICE**

20 Gallon Clay Container ... Model #9412

Designed with strength and durability. Excellent for wet or dry clay and plaster. Will not leak or rust. Hand grips for easy lifting. Flat lid allows you to stack for space-saving storage. Yellow only. Shpg. wt. 8 lbs. (Can ship UPS).....**CALL FOR PRICE**

Dolly ... Model #9413

Easy twist on, twist off to provide mobility.**CALL FOR PRICE**

Mobile Heat Proof Kiln Carts

Mobility and safety are the prime features of these kiln carts. These sturdy rugged carts are made of 16 gauge steel legs with 19 gauge trays. Each of the three trays are covered with non-asbestos millboard to make the handling of projects safe and easy right from the kiln. 4" wheels. Dark Brown. (Can ship UPS)

Model #9500 16" W x 30"D x 32"H Shpg. wt. 60 lbs.**CALL FOR PRICE**

Model #9550 24" W x 36"D x 32"H Shpg. wt. 71 lbs.**CALL FOR PRICE**

Wares Truck ... Model #9605

This truck of 12 gauge steel, welded construction on 4" casters, provides easy mobility of your wares. A variety of uses; excellent for cooling wares after firing or moving from place to place. Can also be used for greenware drying. Furnished with 16 plywood "half shelves" for maximum flexibility each measuring 12" x 28" x 1/2". Overall truck size 24" x 32" x 54" high. Dark Brown. Shpg. wt. 125 lbs. (Can ship UPS).....**CALL FOR PRICE**

Wares Truck W/O Shelves ... Model #9606

Same features as above without plywood shelves. Shpg. wt. 60 lbs**CALL FOR PRICE**

Wedging Board ... Model #9615

480 sq. in. of wedging area! Heavy duty steel 20" x 24" x 2-1/2". Furnished with fine steel cutting wire, and canvas "snap-on" wedging cloth. **Plaster not furnished.** Dark Brown. Shpg. wt. 16 lbs. (Can ship UPS) (Reqs. 70# plaster)**CALL FOR PRICE**

Wedging Stand ... Model #9630

Heavy duty steel table for wedging or kneading clay before forming. Stand is 19"D x 20"W and adjusts from 30" to 36" in height. 20" x 24" x 2-1/2". Wedging Board forms the top surface. **Plaster not furnished.** Furnished with canvas "snap-on" wedging cloth and fine steel cutting wire, with adjustable hook to keep taut. Dark Brown. Shpg. wt. 39 lbs. (Can ship UPS).....**CALL FOR PRICE**

Tray Cabinets

EXCELLENT for wet, fragile and bulky projects. Removable high-impact trays included. Available with or without lockable doors and with or without casters. Dark Brown/Antique Gold doors. (Can ship UPS)

Art Carts:

Ideal for transporting materials from area to area. 4" heavy-duty hard rubber casters, 2 swivel. Overall height 32". Grey.

Model No.	Tray Size (inches)	No. of Trays	Price	Shpg. K.D., Wt. lbs.
AR2-2436		2	Call For Price	47
AR3-2436	24 x 36	3	Call For Price	57
AR2-1630	16 x 30	2	Call For Price	33
AR3-1630		3	Call For Price	41

For one 14" x 20" x 6" drawer, add "D1" to Model No.; for two drawers add "D2." (Example AR2-2436 D1). 24" x 36" Truck holds 1 or 2 drawers. **Drawers are not available for 16" x 30" Truck.** Price per drawer \$99.00 (Can ship UPS).

All Prices F.O.B. Factory

Serving Schools and Studios Since 1939

Call us toll free 1.866.410.CLAY



Art Carts

21 Equipment

SLAB ROLLERS

These sturdy machines are constructed of heavy gauge steel pipe and plate, precision machined parts, permanently sealed bearings and aircraft quality cables. The beds consist of masonite shims which can be removed or added to vary the slab thickness from 1/8" to -1/4" (1" for SRC). A canvas covered removable shim that absorbs water from the clay is used so you can peel off the clay slab easily. The entire shim with clay slab can be removed from the bed. Extra shims available.



SR-20 Slab Roller

The SR-20 is a mid-sized floor model that can produce slabs up to 20"W x 52"L. It includes one 1/4" shim with canvas and one 1/8" plain shim. Maximum slab thickness is 1-1/2". Assembled dimensions: 34"W x 76"L x 40"H. Shown with optional leg assembly.

SR-20 Floor Model.....\$2430.00



SR-36 Slab Roller

The SR-36 is a large floor model that can produce slabs up to 36"W x 52"L. It includes one 1/4" plain shim, one 1/4" shim with canvas, and a 1/8" plain shim. Maximum slab thickness is 1/8". Assembled dimensions: 49"W x 76"L x 40"H.

SR-36 Floor Model.....\$2995.00

IMPORTANT NOTE ON SR-36 SLAB

ROLLER: Because of the amount of clay and the mechanical pressure that is produced rolling a large slab, the middle of the bed may bow slightly, creating a slab that is thinner on the sides. This variation is more evident when rolling thinner slabs—from 1/2" to 3/8". Its affect on thicker slabs is not quite as evident. This is a great slab roller for large projects, but those looking for thin, consistent slabs, may want to purchase one of our smaller slab rollers.



SR-14 Slab Roller

The SR-14 is a large table model that can also be used as a floor model with the optional leg set. It includes two 1/4" shims with canvas and one 1/8" plain shim. Maximum slab dimensions: 14"W x 36"L. Maximum slab thickness is 1-3/4". Assembled dimensions: 27"W x 52"L x 40"H. Shown with optional leg assembly.

SR-14 without leg assembly.... \$1695.00

SR-14 leg assembly 295.00



Mini SRC Slab Roller

Portable, yet extremely sturdy, this slab roller is compact enough to fit on a table and is ideal for small projects (not for production or school use). It has a solid steel frame and the patented cable drive system of the SRC. It includes one 1/4" shim with canvas and two 1/8" plain shims. Maximum slab dimensions: 14"W x 15"L. Maximum slab thickness is 1/4". Assembled dimensions: 31"W x 26"L x 14"H.

Mini SRC Slab Roller.....\$715.00



NEW

Brent Clay Extruder HD

brent®



SRC Slab Roller

The SRC is a portable slab roller designed for small projects (not for production or schools). It can be used on a table or as a floor model with the optional leg set and has a patented cable drive system with opposing rollers that produces even pressure along the bed. The SRC comes with one 1/4" shim with canvas, four 1/4" plain shims and one 1/8" plain shim. Maximum slab dimensions: 21"W x 40"L. Maximum slab thickness is 1-1/4". Assembled dimensions: 40"W x 51"L x 40"H.

SRC without leg assembly \$985.00

SRC leg assembly..... 189.00



Shown with Standard Die Set.

Brent Clay Extruder

The clay extruder makes thousands of different solid or hollow shapes: tubes, bars, tiles, slabs — the possibilities are endless. Constructed with heavy duty steel pipe with wear and stress points case hardened to withstand all production applications. The barrel is 4" wide and holds 10 pounds of clay. An easy-to-remove end cap holds the die you choose. This hand extruder comes with the hardware needed to be bolted to a wall or table and an optional stand can be purchased to attach it to the end of all Brent® SR model slab rollers. The HD model mounts to the wall. A three piece standard die set is available for a variety of solid shapes. For more intricate use of the hand extruder, a tube die set is available to make hollow round, hexagonal and square extrusions.

Clay Extruder \$580.00

Clay Extruder HD 570.00

Standard Die Set 56.00

Hollow Die Set..... 130.00

Pug Mills

Equipment 22

Venco De-Airing Pug Mills

Venco uses the highest quality materials in the construction of the pug mills to ensure a long and reliable service life. Venco manufacture three different series of pugmills. The Mk2 models comprise a thick section, marine grade, aluminium barrel and a single stainless steel auger. The new Super-twin's barrel and auger is constructed entirely from stainless steel. This unit has an innovative twin auger mixing chamber which leads to a single auger extruder. The very largest Industrial Series pugs manufactured by Venco are also constructed entirely from stainless steel. On all models stainless steel bolts are used whenever there is the possibility of corrosion. These materials are chosen to minimise chances of clay contamination by corrosion of the barrel or auger.

- Robust, suitable for de-airing, blending, mixing, and reworking clay.
- Stainless steel mixer shaft and blades.
- Main mixer shaft bearings — sealed ball races, lubricated for life, protected by triple "O" ring seals.
- 240 volt system (single phase).
- Cast aluminum barrel — split longitudinally for easy cleaning.
- Available in 3 inch or 4 inch nozzle.

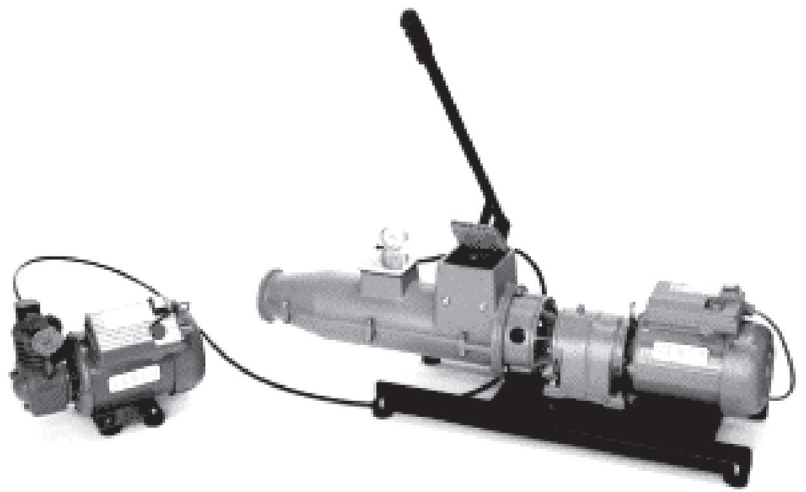

4 inch nozzle.....Call
 3-1/2 inch nozzle.....Call
 3 inch nozzle.....Call

Plus Freight Charges – Call For Estimate F.O.B. Columbus Ohio

The Peter Pugger-Mixer

The Pugger-Mixer makes clay mixing quick and easy. Just add water to a batch of dry ingredients in the mixing chamber. Allow the powerful mixing action to completely homogenize the clay body, then switch to pugging action and the Pugger-Mixer unloads itself thru the pugmill, leaving the operator free to cut off and handle the extrusion. Clay handling is greatly reduced without the heavy labor of transferring wet clay from separate mixer to independent pugmill. This saves hours and effort in production. Knowing the true composition of the working clay and convenient salvaging of scrap gives the Pugger-Mixer owner both product control and economy with a single space-saving machine costing little more than individual mixer or pugmill.

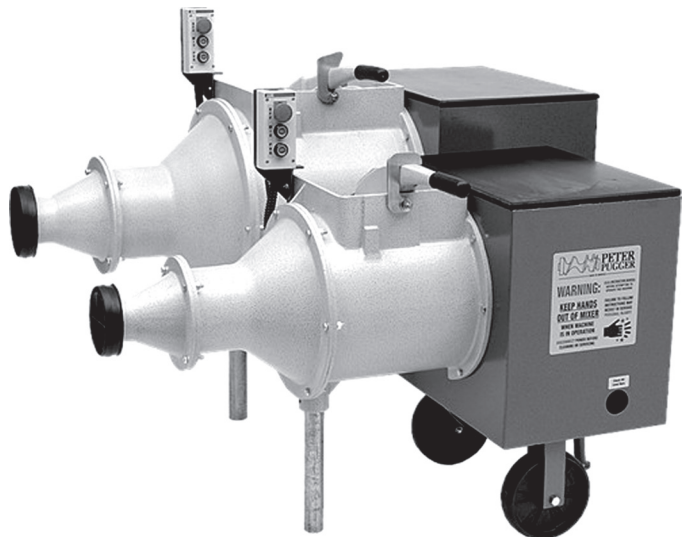

Specifications

Model	PM50	PM100
Recommended Maximum Batch (dry powder)	50 pounds	100 pounds
Pug Size	3 inch round	4 inch round
Overall dimensions	46"L x 20"W x 30"H	58"L x 26"W x 33"H
Standard Motor	2 HP 1 phase 220 Volt 12 Amp	3 HP 1 phase 220 Volt 16 Amp
Extension Cord Wire Size (25 feet max.)	#12	#10
Gear Reducer Oil Capacity	1 pint	2.5 pints
Mixing Rate	300# per hour	600# per hour
Pugging Rate	1200# per hour	2000# per hour
Shipping Weight	415#	625#

3 phase motors available on special order.

Prices

Cat. No./Model	CCC Price
PM50SS*	Call
PM100SS*	Call

Plus Freight Charges – Call For Estimate F.O.B. Columbus Ohio

Call us toll free 1.866.410.CLAY

Serving Schools and Studios Since 1939

23 Glazes

Columbus Clay Stoneware Glazes Dry cone 4-6

<u>Number</u>	<u>Name</u>	<u>Description</u>	<u>Price</u>
417	Cherry Amber Red	Gloss semi-transparent fire engine true red glaze	G
421	Mango	Gloss semi-transparent bright orange glaze	G
425	Lemon Yellow	Gloss semi-opaque bright lemon yellow glaze	G
435	Ox Blood	A classic iron saturated glaze with shades of red, brown, and green	D
501	Clear	Gloss transparent glaze	C
502	White Enamel	Gloss white opaque glaze	D
503	Ultramarine Blue	Gloss deep cobalt blue glaze	E
505	Midnight Black	Gloss black semi-opaque glaze	E
508	Sea Green Pearl	Semi-gloss blue green rutile glaze	E
606	Yellow Silk	Gloss light yellow transparent glaze	E
701	Bone Dry	Very matt off white opaque glaze	A
702	Speckled Bone Dry	Very matt off white w/specks glaze	A
801	Cinnamon Ivory Speck	Gloss orange/brown iron breakup	E
901	Clear Crackle	Gloss crackle glaze	B
FB	Floating Blue	Classic blue cobalt float glaze with rutile and iron	E
CM	Copper Matt	Fires to the color and texture of weathered copper	E

Note: Please visit www.columbusclay.com for these stoneware glaze color charts

Price Chart

<u>Category</u>	<u>1-4#</u>	<u>5#</u>	<u>25#</u>
A	\$6.00	\$24.00	\$96.00
B	\$6.50	\$26.00	\$104.00
C	\$7.00	\$29.00	\$116.00
D	\$7.50	\$30.00	\$120.00
E	\$8.00	\$32.00	\$128.00
G	\$8.50	\$39.00	\$156.00

Columbus Clay Raku Glazes Dry cone 06

Glazes 24

<u>Number</u>	<u>Name</u>	<u>Description</u>	<u>Price</u>
301	White Crackle Raku	Satin white crackle with small to large cracks along the surface	A
302	Copper Red Raku	Variegated red and copper glaze in reduction	C
303	Oribe Copper Luster Raku	A beautiful copper glaze in reduction and a deep iridescent green in oxidation	C
304	Setoguro Black Raku	Variegated black with metallic reds, blues, purples, and coppers in reduction and glossy back in oxidation	D
306	Iyokan Orange Raku	Glossy mottled orange glaze in oxidation	G
307	Okame Red	Gloss mottled red glaze in oxidation	G
308	Ume Plum Raku	Glossy mottled plum purple glaze in oxidation	G

Note: please visit www.columbusclay.com for these raku glaze color charts

Price Chart

<u>Category</u>	<u>1-4#</u>	<u>5#</u>	<u>25#</u>
A	\$5.50	\$22.00	\$89.00
C	\$6.50	\$26.00	\$104.00
D	\$7.00	\$28.00	\$112.00
G	\$7.75	\$31.00	\$124.00

Columbus Clay Engobe Cone 5 (dry bisque slip)

This white clay slip is a great base for lining vessels, sgraffito work or adding your own colors to make your own unique colored clay slips (engobes or underglazes). Works well on moist mid-range stoneware or porcelain bodies. Be sure to test on the clay body you use. (see pages 10-13 for stains)

1 lb.....\$4.50

Underglaze Pencils

These look like actual pencils only the leads are made out of ceramic stains. When you write or draw on bisque ware and overglaze with a clear or translucent glaze the decoration is permanent. What a creative tool! Six colors available, Yellow, Blue, Green, Rose, Brown, Black.

Individual Pencils.....\$12.50

Six Color Set.....\$68.00

Over Glaze Lustres

Actual precious metals dissolved in aromatic oils and solvents. Brush on a fired glossy glaze and refire to cone 020 - 018. The results are amazing as 24k gold and platinum bonds to the glaze. Commonly used to band cups or plates on fine china, the possibilities are huge for this unique material. Four lustres available, Gold, Platinum, Mother of Pearl, Essence of Gold.

Liquid Gold cone 018, 11% Top Grade, 2gm (price subject to change).....CALL FOR PRICE

Liquid Platinum cone 018, 2gm (price subject to change).....CALL FOR PRICE

Mother of Pearl cone 020-019, 1/2oz.....\$7.50

Essence of Gold Thinner/Conditioner, 1/2oz.....\$6.95

Gold and platinum are available in bulk quantities, please call for quote

25 Glazes

AMACO® Gloss Glazes

Cone 05 Lead Free. Gloss Glazes fire to a smooth, glossy finish. The vibrant colors provide a durable, craze resistant surface that makes this series ideal for utilitarian projects for students or production potteries. The LG series is formulated for brushing application but can be adjusted to work in pouring, dipping, and sponging. Slow fire for best results.

Cat. No.		Pint Liquid
LG-1	Black Magic (1)	\$16.50
LG-10	Clear Transparent (1)	12.80
LG-11	Opaque White (1)	14.40
LG-14	Gray (1)	15.90
LG-20	Medium Blue (1)	15.90
LG-21	Dark Blue (1)	18.50
LG-23	Robin's Egg (1)	15.90
LG-24	Light Blue (1)	15.90
LG-30	Chocolate Brown (1)	16.50
LG-32	Metallic Brown (3)	16.50
LG-34	Red Brown (1)	18.50
LG-36	Freckled Brown (3)	18.50
LG-40	Dark Green (1)	15.90
LG-42	Light Green (1)	15.90
LG-48	Chrome Green (1)	15.90
LG-50	Maroon (1)	21.50
LG-51	Lilac (1)	18.50
LG-52	Petal Pink (1)	15.90
LG-54	Mulberry Red (1)	18.50
LG-55	Purple (1)	21.50
LG-57	Intense Red (1)	21.50
LG-58	Brilliant Red (1)	21.50
LG-59	Hot Red (1)	21.50
LG-60	Dark Yellow (1)	15.90
LG-61	Canary Yellow (1)	15.90
LG-62	Light Yellow (1)	15.90
LG-63	Brilliant Yellow (1)	15.90
LG-65	Amber (1)	18.50
LG-67	Fire Orange (1)	21.50
LG-68	Vivid Orange (1)	21.50
LG-760	Pale Yellow (1)	15.90

Cat. No.		Pint Liquid
LG-2	Black Lustre (1)	16.50
LG-25	Turquoise Green (1)	15.90
LG-26	Turquoise (1)	15.90
LG-27	Turquoise Crackle (4)	15.90
LG-44	Olive Green (1)	15.90
LG-45	Emerald Green (1)	15.90
LG-46	Leaf Green (1)	15.90

Cat. No.		Gallon Liquid
LG-1	Black Magic (1)	84.00
LG-10	Clear Transparent (1)	47.50
LG-11	Opaque White (1)	71.00
LG-20	Medium Blue (1)	77.00
LG-21	Dark Blue (1)	91.50
LG-24	Light Blue (1)	77.00
LG-32	Metallic Brown (3)	84.00
LG-48	Chrome Green (1)	77.00
LG-52	Petal Pink (1)	77.00
LG-55	Purple (1)	104.00
LG-58	Brilliant Red (1)	104.00
LG-61	Canary Yellow (1)	77.00
LG-65	Amber (1)	90.00
LG-67	Fire Orange (1)	101.00

Cat. No.		Pint Liquid
LG-46	Leaf Green (1)	75.00

LG Class Pack 6 colors	107.00
LG Class Pack #1 12 colors	192.00
LG Class Pack #2 12 colors	210.00
LG Class Pack K-6 12 colors	181.00

AMACO® Artist's Choice Glazes

Cone 05 Lead Free. Cone 05 oxidation glazes look like high fired reduction stoneware. They can be fired over and earthenware clay, however they look their best over dark or red firing clay. The color in the clay will partially show through the texture and add another color dimension to glaze.

Cat. No.		Pint Liquid
A-24	Exotic Blue (1)	\$11.15
A-28	Peacock (1)	11.15
A-34	Sand Bar	11.15
A-43	Green Float	11.15
A-52	Old Brick	15.45
A-61	Moss Brown	15.45
A-62	Camel (1)	11.15
A-66	Burnt Orange	15.45

Cat. No.		Pint Liquid
A-22	Aztec Turquoise (1)	11.15
A-32	Iron Saturate (1)	11.15
A-40	Seafoam Green (1)	11.15

A-Class Pack No. 1 6 Colors	56.00
A-Class Pack No. 2 6 Colors	67.00

AMACO® Matt Glazes

Cone 05 Lead Free. Dinnerware-safe Matt Glazes provide a smooth, satin finish for decorative art pottery and tile. Because these glazes are nonflowing, they are adaptable for many unique decoration techniques.

Cat. No.		Pint Liquid
LM-1	Satin Black (1)	\$15.00
LM-10	Transparent Matt (1)	15.00
LM-11	Opaque White (1)	15.00
LM-13	Terra Cotta (1)	15.00
LM-15	Dove Gray (1)	15.00
LM-16	Elephant Hide (1)	15.00
LM-20	Blue Iris (1)	15.00
LM-21	Sky Blue	15.00
LM-25	Robin Egg Blue (1)	15.00
LM-30	Cocoa Brown (1)	15.00
LM-32	Red Brown (1)	15.00
LM-41	Chartreuse	15.00
LM-42	Parakeet Green (1)	15.00
LM-46	Dark Green (1)	15.00
LM-50	Burgundy (1)	20.50
LM-52	Pink (1)	15.00
LM-53	Orchid (1)	15.00
LM-54	Coral (1)	20.50
LM-56	Red (1)	20.50
LM-58	Purple (1)	15.00
LM-60	Daffodil Yellow (1)	15.00
LM-61	Soft Yellow	15.00
LM-65	Butterscotch (1)	20.50
LM-66	Orange (1)	20.50
LM-67	Tangerine	15.00
LM-231	Chestnut Brown (1)	15.00
LM-244	Blue Green (1)	15.00

LM Class Pack No. 1 6 colors	93.00
LM Class Pack No. 2 6 colors	93.00
LM Class Pack 12 colors	182.00

AMACO® Opalescent Glazes

Cone 05 Lead Free. Dinnerware-safe Opalescent Glazes develop their greatest opalescence and most interesting textures when applied over red clay. On textured ware, the glaze flows thin on relief and thick in incised areas, illuminating dimension. On red bisque, these glazes should be applied more heavily than on other colors of clay. A slow firing is best.

Cat. No.		Pint Liquid
O-10	Transparent Pearl (1)	\$15.40
O-11	White Clover (1)	15.40
O-12	Tawny (1)	15.40
O-30	Autumn Leaf (1)	15.40
O-42	Moss Green (1)	15.40
O-52	Fuchsia (1)	15.40
O-54	Dusty Rose (1)	15.40
O-57	Mottled Burgundy (1)	15.40

Cat. No.		Pint Liquid
O-2	Black Tulip (1)	15.40
O-20	Bluebell (1)	15.40
O-21	Aquamarine (1)	15.40
O-23	Sapphire Blue (1)	15.40
O-26	Turquoise (1)	15.40

O-Class Pack 6	78.00
----------------	-------

AMACO® Stone Texture Glazes

Cone 05 Lead Free. Create a smooth, variegated stone-like surface by firing over a textured Cone 04 bisque surface, such as relief tiles. Vintage "mottled" pottery looks are achieved because ST's move and flow to accentuate textures.

Cat. No.		Pint Liquid
ST-20	Blue	\$13.45
ST-30	Rust	13.45
ST-33	Straw	13.45
ST-51	Peach	13.45
ST-53	Ivory Beige	13.45
ST-55	Lavender	13.45
ST-56	Violet	13.45
ST-65	Burnt Orange	13.45

Cat. No.		Pint Liquid
ST-23	Light Blue	13.45
ST-25	Blue-Gray	13.45
ST-40	Green	13.45
ST-42	Olive	13.45

ST Class Pack 6 Colors	67.00
------------------------	-------



AMACO® Crystaltex Glazes

Cone 05 Lead Free. AMACO® Crystaltex Glazes create bursts of color which contrast and blend with the base glaze, resulting in a spontaneous range of color. Multi-color effects can be subtle or bold. Crystals fan out on flat horizontal surfaces and run on vertical pieces.

Cat. No.		Pint Liquid
CTL-1	Jet Moss	\$19.20
CTL-3	Lava	19.20
CTL-9	Snap Dragon	19.20
CTL-10	Fu Manchu	19.20
CTL-11	Snow Fire	19.20
CTL-12	Mardi Gras	19.20
CTL-15	Moon Scape	19.20
CTL-22	Milky Way	23.30
CTL-23	Moody Blue	23.30
CTL-30	Singed Maple	23.30
CTL-31	Brown Earth	19.20
CTL-32	Chocolate Chip	23.30
CTL-34	Granada	23.30
CTL-35	Nutmeg	23.30
CTL-36	Ginger Bread	23.30
CTL-37	Desert Tortoise	23.30
CTL-39	Yellow Universe	23.30
CTL-40	Forest	23.30
CTL-41	Melon	19.20
CTL-42	Fantasia	19.20
CTL-43	Aurora	19.20
CTL-44	Turritella	23.30
CTL-45	Sunset Jewel	23.30
CTL-46	Ultramarine Jewel	19.20
CTL-47	Tangerine Dream	23.30
CTL-48	Sun and Sea	23.30
CTL-49	Azurite	23.30
CTL-52	Watsonia Red	23.30
CTL-54	Firecracker	23.30
CTL-61	Buttercup	19.20
CTL-67	Summer Mango	23.30
CTL-69	Sassy Saffron	23.30
CTL-70	Magnolia Jewel	23.30
CTL-71	Purple Blaze	23.30

CTL-20	Royal Turquoise	19.20
CTL-26	Sea Mist	19.20

CTL Class Pack No.1 6 Colors	252.00
CTL Class Pack No.2 6 Colors	117.00
CTL Class Pack No.3 6 Colors	127.00
CTL Class Pack No.4 12 Colors	252.00

AMACO® Teachers Choice Low Fire Glazes

Cone 05. AMACO® Teacher's Choice® (TC) gloss glazes are completely intermixable so they can be blended with each other or with any of the AMACO® Teacher's Palette® (TP) glazes to create an infinite color palette. The eight TC glazes are AP NON-TOXIC, LEAD FREE, dinnerware safe, bright and colorful, and are safe for use by artists of any age.

Cat. No.		Gallons
TC-1	Black	\$62.00
TC-11	White	62.00
TC-21	Blue	62.00
TC-32	Brown	62.00
TC-41	Green	62.00
TC-58	Red	62.00
TC-60	Yellow	62.00
TC-64	Orange	62.00

AMACO® Alligator Glazes

Cone 05 Lead Free. No two pieces glazed with AMACO LT Textured Alligator Glazes are ever alike due to the many variations in texture which occur in firing. This surprising quality makes this series a great choice for original work.

Cat. No.		Pint Liquid
LT-12	Speckled Green	\$15.00
LT-13	Dalmation (1)	15.00
LT-15	Speckled Blue Gray (1)	15.00
LT-17	Liana Gray (4)	18.95
LT-34	Antique Brown (4)	19.50
LT-132	Jewel Brown (1)	18.95
LT-147	Yellow Green (4)	20.50
LT-161	Tiger Eye (4)	20.50
LT-166	Mottled Orange (4)	20.50

Cat. No.		Pint Liquid
LT-3	Old Pewter (1)	19.50
LT-16	Green Stone (1)	15.00
LT-22	Tahitian Blue (4)	15.00
LT-48	Moss Agate (4)	19.50

LT Class Pack 6	102.00
-----------------	--------



AMACO® F-Series Glazes

Cone 05 Lead Free. The F Series Glazes intense and brilliant colors make it a best seller. The F-Series is a semi-opaque and fires to a high gloss finish which makes it ideal for dinnerware.

Cat. No.		Pint Liquid
F-1	Jet Black	\$16.00
F-10	Clear Transparent	14.00
F-11	White	16.00
F-15	Warm Gray	16.00
F-20	Light Blue	16.00
F-21	Navy	16.00
F-22	Royal Blue	17.00
F-23	Vivid Blue	17.00
F-25	Turquoise	17.00
F-30	Chocolate	16.00
F-40	Chrome Green	16.00
F-41	Light Green	16.00
F-42	Celadon	16.00
F-43	Evergreen	16.00
F-50	Rose	20.00
F-51	Mauve	16.00
F-52	Burgundy	20.00
F-53	Sand	16.00
F-54	Peach	16.00
F-55	Pink	16.00
F-57	Coral	23.00
F-58	Red	23.00
F-60	Golden Yellow	16.00
F-61	Lemon Yellow	16.00
F-65	Amber	16.00
F-66	Orange	23.00
F-70	Violet	23.00
F-71	Amethyst	23.00
<hr/>		
F-26	Aqua	16.00
F-27	Nairobi Blue	16.00
F-47	Christmas Tree Green	16.00
<hr/>		
		Gallon Liquid
F-10	Clear Transparent (1)	58.00
F-11	White	79.00
<hr/>		
F Series Class Pack 6		108.00
F Series Class Pack 12		204.00

AMACO® Semi-Moist Underglaze Colors — Lead Free

These concentrated one-stroke colors in convenient pan form, are especially recommended for ceramic water color effects and for detail painting. May be applied on greenware or bisque. Transparent glazes F-10, LG-10 or HF-10, are suggested for use over decoration.

Cat. No.	Description	Price
Set No. 108	8 whole pans: Maroon, Light Yellow, Dark Blue, Blue-Green, Dark Green, Black, Light Brown, White, in hinged plastic box, per set	\$32.00
Set No. 109	8 whole pans: Lilac, Turquoise, Medium Blue, Pink, Warm Gray, Mahogany Brown, Bright Yellow, Irish Green, in hinged plastic box, per set	\$32.00
Set No. 110	8 whole pans: Purple, Light Blue, Aqua, Rose, Orange, Peach, Chartreuse, Sun Tan, in hinged plastic box, per set	\$32.00
Set No. 111	8 whole pans: Electric Blue, Amethyst, Violet, Red, Light Red, Salmon, Real Orange, Hunter Green, in hinged plastic box, per set	\$31.00
Refills:	All colors for sets 108, 109, 110 and 111 each (SPECIAL ORDER)	\$3.49

AMACO® Engobes

In 1 lb. dry jars. Lead Free

Cat. No.		1 lb. dry
SE-701	Natural Black	\$15.50
SE-702	Jet Black	17.95
SE-710	White	12.40
SE-720	Dark Blue	17.60
SE-730	Red Brown	12.90
SE-731	Natural Brown	12.90
SE-732	Dark Buff	12.90
SE-740	Dark Green	12.90
SE-760	Yellow	12.90

AMACO® Liquid Underglaze Decorating Colors — Lead Free

Concentrated opaque liquid colors in ready-to-use form, these colors cover large areas quickly and smoothly. Their opacity counteracts streaking. May be applied on greenware or bisque. Transparent glazes F-10, LG-10 or HF-10, are suggested for use over decoration.

Cat. No.		2 Fluid Ounces
* LUG 1	Black (1)	\$6.60
* LUG 10	White (1)	6.60
* LUG 15	Warm Gray (1)	6.60
* LUG 20	Light Blue (1)	6.60
* LUG 21	Medium Blue (1)	6.60
* LUG 22	Dark Blue (1)	6.60
* LUG 25	Turquoise (1)	6.60
* LUG 26	Aqua (1)	6.60
* LUG 30	Light Brown (1)	6.60
* LUG 31	Mahogany Brown (1)	6.60
* LUG 40	Chartreuse (1)	6.60
* LUG 41	Irish Green (1)	6.60
* LUG 42	Blue Green (1)	6.60
* LUG 43	Dark Green (1)	6.60
* LUG 50	Pink (1)	6.60
* LUG 51	Rose (1)	6.60
* LUG 52	Peach (1)	6.60
* LUG 53	Sun Tan (1)	6.60
* LUG 54	Lilac (1)	6.60
* LUG 55	Purple (1)	6.60
* LUG 56	Maroon (1)	6.60
* LUG 58	Dark Red (1)	6.60
* LUG 60	Light Yellow (1)	6.60
* LUG 61	Bright Yellow (1)	6.60
* LUG 65	Orange (1)	6.60

Cat. No.		Pint Liquid
* LUG 1	Black (1)	\$24.00
* LUG 10	White (1)	24.00
* LUG 15	Warm Gray (1)	24.00
* LUG 20	Light Blue (1)	24.00
* LUG 21	Medium Blue (1)	24.00
* LUG 22	Dark Blue (1)	24.00
* LUG 25	Turquoise (1)	24.00
* LUG 26	Aqua (1)	24.00
* LUG 30	Light Brown (1)	24.00
* LUG 31	Mahogany Brown (1)	24.00
* LUG 40	Chartreuse (1)	24.00
* LUG 41	Irish Green (1)	24.00
* LUG 42	Blue Green (1)	24.00
* LUG 43	Dark Green (1)	24.00
* LUG 50	Pink (1)	24.00
* LUG 51	Rose (1)	24.00
* LUG 52	Peach (1)	24.00
* LUG 53	Sun Tan (1)	24.00
* LUG 54	Lilac (1)	24.00
* LUG 55	Purple (1)	24.00
* LUG 56	Maroon (1)	24.00
* LUG 58	Dark Red (1)	24.00
* LUG 60	Light Yellow (1)	24.00
* LUG 61	Bright Yellow (1)	24.00
* LUG 65	Orange (1)	24.00
* LUG Class Pack 6		135.00
* LUG Class Pack 12		250.00

AMACO® SuspendAid.....\$8.60

AMACO® Liquid Underglaze Decorating Color Sets — Lead Free

Cat. No.	Description	Price
Set No. 712	12, 2 fluid ounce jars: Black, White, Light Blue, Dark Blue, Aqua, Light Brown, Blue-Green, Dark-Green, Rose, Peach, Maroon, Light-Yellow, per set	\$75.00
Set No. 812	12, 2 fluid ounce jars: Warm-Gray, Medium Blue, Turquoise, Mahogany Brown, Chartreuse, Irish-Green, Pink, Sun Tan, Lilac, Purple, Bright Yellow, Orange, per set	\$75.00

AMACO® K-6 Sampler Class Pack Set

Cone 06-04. A collection of low fire glazes, two colors each form six popular AMACO glaze series. Class Pack K-6 Sampler 12\$187.00

Glazes 26

AMACO® Velvet Underglazes

Mix and layer hundreds of colors! Their saturated color, dependability and versatility make Velvets as popular for pros as they are for children. velvets fire true-to-color as a Cone 05/06 underglaze or fired to Cone 6. Try two finish possibilities: When left unglazed, these colors have the rich, textural appearance of velvet; when covered with AMACO Clear transparent Matt or Clear Gloss glaze, they intensify in color.

Cat. No.		2 Fluid Ozs.	Pint Liquid
V-301	Ivory Beige	\$4.70	\$17.95
V-302	Beige	4.70	—
V-303	Terra Cotta	4.70	17.95
V-304	Straw	4.70	17.95
V-308	Yellow	4.70	17.95
V-309	Deep Yellow	4.70	17.95
V-310	Tan	4.70	—
V-313	Red Brown	4.70	17.95
V-314	Chocolate Brown	4.70	17.95
V-315	Peach	5.10	17.95
V-316	Light Pink	5.10	18.95
V-318	Rose	5.10	18.95
V-320	Lavender	6.10	39.95
V-321	Lilac	5.10	18.95
V-322	Purple	5.10	18.95
V-323	Salmon	5.10	18.95
V-325	Baby Blue	4.70	17.95
V-326	Medium Blue	4.70	17.95
V-327	Turquoise Blue	4.70	17.95
V-328	Iceberg Blue	4.70	—
V-332	Teal Blue	4.70	17.95
V-333	Avocado	4.70	17.95
V-334	Flaxen	4.70	—
V-336	Royal Blue	7.20	39.95
V-341	Blue Green	5.10	18.95
V-343	Chartreuse	4.70	17.95
V-345	Light Green	4.70	17.95
V-350	Orange	4.70	17.95
V-353	Dark Green	4.70	17.95
V-354	Leaf Green	4.70	17.95
V-355	Shadow Green	4.70	—
V-356	Pearl Gray	4.70	—
V-357	Dark Gray	4.70	—
V-360	White	4.70	17.95
V-361	Jet Black	4.70	17.95
V-366	Teddy Bear Brown	4.40	17.95
V-367	Mist Gray	4.40	—
V-368	Antique Ivory	4.70	—
V-369	Fawn	4.70	—
V-370	Velour Black	6.29	18.95
V-371	Rosy Mauve	4.70	—
V-372	Mint Green	4.70	17.95
V-373	Medium Brown	4.70	—
V-374	Royal Peach	4.70	—
V-375	Maroon	7.20	39.95
V-376	Hunter Green	4.70	17.95
V-380	Violet	7.20	39.95
V-381	Amethyst	7.20	39.95
V-382	Red	7.20	39.95
V-383	Light Red	7.20	39.95
V-384	Real Orange	7.20	39.95
V-385	Cinnamon	4.70	17.95
V-386	Electric Blue	4.70	17.95
V-387	Bright Red	7.20	39.95
V-388	Radiant Red	7.20	39.95
V-389	Flame Orange	7.20	39.95
V-390	Bright Orange	7.20	39.95
V-391	Intense Yellow	7.20	39.95
V-Class Pack 6 Colors		145.00	
V-Class Pack 12 Colors		300.00	

Cat. No.	Each
Velvet kit 1 12 Colors 2 oz Jars	50.00
Velvet kit 2 12 Colors 2 oz Jars	50.00
Velvet kit 3 12 Colors 2 oz Jars	50.00
Velvet kit 4 12 Colors 2 oz Jars	50.00

27 Glazes

AMACO® Underglaze Decorating Pencils

Ideal for shading, fine line drawing, or identification. Apply to bisque ware to create a variety of unique decorative designs. Maximum firing temperatures is Cone 10 for Blue and Green, Cone 5 for all other colors. Yellow and Brown will fire lighter and Black will turn Green at Cone 5. Black will turn Green at Cone 10.

Cat. No.	Description	Price
	Black.....	\$12.90
	Brown.....	12.90
	Blue.....	12.90
	Green.....	12.90
	Rose.....	12.90
	Yellow.....	12.90
	Set: One of each color.....	71.00

AMACO® Textured Clay Rollers

4" wide

Cat. No.	Description	Price
16003C	Loi Fish w/handle.....	\$8.95
16004D	Pre-Columbian w/handle.....	8.95
16002B	Tribal w/handle.....	8.95
16001A	Vine Leaf w/handle.....	8.95
16015T	Diamond w/handle.....	8.95
16014R	Bamboo w/handle.....	8.95
	Sleeves: can be ordered separately for each.....	4.75

AMACO® Mid/High Fire "SM"

Satin Matte Glazes for Bisque

Cone 05-06

Cat. No.	Pints	Price
SM-1	Black.....	\$12.40
SM-10	Clear.....	12.40
SM-11	White.....	12.40
SM-20	Light Blue.....	12.40
SM-21	Dark Blue.....	12.40
SM-26	Turquoise.....	12.40
SM-27	Teal.....	13.95
SM-32	Textured Tan.....	12.40
SM-34	Red Brown.....	12.40
SM-42	Mint.....	12.40
SM-44	Chartreuse.....	12.40
SM-51	Red.....	12.40
SM-63	Yellow.....	12.40
SM-68	Orange.....	12.40

AMACO® Shino Glazes Cone 5

Influenced by the humble earthiness of tea ceremony bowls, Amaco Shino glazes give a traditional high-iron look to any high fire clay body. Beautiful on textured or smooth clay bodies, blendable to get the right degree of matte or glossy surface. Shino glazes can also be layered with our PC line of glazes for different effects. Suitable for Red or White Clay. Food safe. Cone 5.

Cat. No.	Pints	Price
SH-11	Chai Gloss.....	\$11.40
SH-12	Chai Matte.....	11.40
SH-21	Acai Gloss.....	11.40
SH-22	Acai Matte.....	11.40
SH-31	Cacao Gloss.....	11.40
SH-32	Cacao Matte.....	11.40
SH-41	Oolong Gloss.....	11.40
SH-42	Oolong Matte.....	11.40
SH-45	Matcha Gloss.....	11.40
SH-46	Matcha Matte.....	11.40
SH-51	Hibiscus Gloss.....	11.40
SH-52	Hibiscus Matte.....	11.40

AMACO® Sahara High Fire Glazes

Cone 4-6 Lead Free. The Majority of this line has been discontinued by Amaco. HF-9, 10, 11, 55 & 56 will remain. As of the mailing of this catalog we have inventory on the rest of the colors. As stock is depleted the glazes will no longer be available. We are stocking the new exciting line of Amaco Celadon and Satin Matte line of Med / High fire glazes.

Cat. No.	Description	Pint Liquid
HF-1	Black.....	\$12.95
HF-9	Zinc Free-Clear.....	12.40
HF-10	Clear.....	11.40
HF-11	White.....	11.40
HF-12	Clear Satin.....	12.40
HF-13	White Matt.....	12.40
HF-14	Oatmeal.....	12.40
HF-17	Waxy White.....	12.40
HF-18	Gray.....	12.40
HF-21	Ultramarine Blue.....	12.40
HF-22	Textured Blue.....	12.40
HF-23	Textured Gray Blue.....	12.40
HF-24	Teal Blue.....	12.40
HF-30	Brown.....	12.40
HF-31	Rust Brown.....	12.40
HF-32	Textured Tan.....	12.40
HF-36	Textured Amber Brown.....	12.40
HF-37	Textured Amber.....	12.40
HF-50	Glossy Burgundy.....	16.50
HF-51	Peach.....	12.40
HF-52	Hazy Pink.....	16.50
HF-53	Lavender.....	16.50
HF-54	Purple.....	16.50
HF-55	Coral Gloss.....	24.80
HF-56	Red Gloss.....	24.80
HF-57	Coral Matt.....	24.80
HF-58	Red Matt.....	24.80
HF-60	Yellow.....	12.40
HF-62	Matt Yellow Oatmeal.....	12.40
HF-63	Textured Almond.....	12.40

Cat. No.	Description	Pint Liquid
HF-26	Turquoise (1).....	12.40
HF-41	Dark Green (1).....	10.95

Cat. No.	Description	Gallon Liquid
HF-9	Zinc Free-Clear (1).....	61.00
HF-10	Clear (1).....	40.25
HF-11	White (1).....	40.25

HF-159	Burgundy (1).....	18.50
HF-161	Bright Yellow (1).....	18.50
HF-164	Pink (1).....	14.40
HF-165	Scarlet Red (1).....	24.80
HF-166	Orangerie (1).....	24.80
HF-167	Clementine (1).....	24.80
HF-170	Lilac (1).....	18.50
HF-171	Amethyst (1).....	24.80

Cat. No.	Description	Pint Liquid
HF-125	Turquoise (1).....	13.95

HF Class Pack 12 #1..... 159.00

AMACO® Potter's Choice Glazes Cone 5-6

Cat. No.	Description	Pint Liquid	Gallon	25 lbs. Dry
PC-12	Blue Midnight.....	\$11.30	\$57.00	\$180.00
PC-20	Blue Rutile.....	11.30	58.00	160.00
PC-21	Artic Blue.....	11.30	58.00	160.00
PC-23	Indigo Float.....	11.30	58.00	160.00
PC-27	Tourmaline.....	11.30	58.00	160.00
PC-28	Frosted Turquoise.....	11.30	58.00	200.00
PC-29	Deep Olive Speckle.....	11.30	58.00	200.00
PC-30	Temmokku.....	11.30	58.00	160.00
PC-31	Oatmeal.....	11.30	58.00	160.00
PC-32	Albany Slip Brown.....	13.85	72.00	198.00
PC-33	Iron Luster.....	11.30	58.00	160.00
PC-34	Light Sepia.....	11.30	58.00	160.00
PC-35	Oil Spot.....	11.30	58.00	160.00
PC-36	Iron Stone.....	11.30	58.00	160.00
PC-37	Smoked Sienna.....	11.30	58.00	160.00
PC-39	Umber Float.....	11.30	58.00	160.00
PC-43	Toasted Sage.....	11.30	58.00	160.00
PC-45	Dark Green.....	11.30	58.00	160.00
PC-48	Art Deco Green.....	11.30	58.00	220.00
PC-50	Shino.....	11.30	58.00	160.00
PC-52	Deep Sienna Speckle.....	11.30	58.00	220.00
PC-53	Ancient Jasper.....	11.30	58.00	160.00
PC-55	Chun Plum.....	14.90	78.00	220.00
PC-57	Smokey Merlot.....	14.90	78.00	260.00
PC-59	Deep Firebrick.....	11.30	58.00	220.00
PC-60	Salt Buff.....	11.30	58.00	160.00
PC-62	Text. Amber Brown.....	11.30	58.00	160.00

PC-1	Saturation Metallic (1).....	20.00	99.00	290.00
PC-2	Saturation Gold (1).....	11.30	58.00	150.00
PC-4	Palladium.....	11.30	58.00	160.00
PC-25	Textured Turquoise (1).....	11.30	58.00	160.00
PC-40	True Celadon (1).....	11.30	58.00	160.00
PC-41	Vert Lustre.....	11.30	58.00	160.00
PC-42	Seaweed (1).....	11.30	58.00	170.00
PC-46	Lustrous Jade (1).....	11.30	58.00	160.00
PC-49	Frosted Melon.....	11.30	58.00	160.00

PC Class Pack #1 6 colors.....\$60.00
 PC Class Pack #2 6 colors.....68.00
 PC Class Pack #3 6 colors.....60.00
 PC Class Pack #4 6 colors.....60.00

AMACO® Celebration High Fire Glazes

Cone 5-6 Lead Free. Celebration Glazes are a beautiful group of bright and pastel colors for stoneware that are as colorful as earthenware glazes.

Cat. No.	Description	Pint Liquid
HF-115	Light Gray (1).....	\$18.50
HF-120	Dark BlueBric (1).....	24.60
HF-127	China Blue (1).....	23.95
HF-128	Teal (1).....	18.50
HF-129	Baby Blue (1).....	14.40
HF-133	Deco Brown (1).....	14.40
HF-134	Straw (1).....	13.95
HF-140	Green (1).....	12.40
HF-142	Chartreuse (1).....	18.50
HF-159	Burgundy (1).....	18.50
HF-161	Bright Yellow (1).....	18.50
HF-164	Pink (1).....	14.40
HF-165	Scarlet Red (1).....	24.80
HF-166	Orangerie (1).....	24.80
HF-167	Clementine (1).....	24.80
HF-170	Lilac (1).....	18.50
HF-171	Amethyst (1).....	24.80

Cat. No.	Description	Pint Liquid
HF-125	Turquoise (1).....	13.95

HF Class Pack 12 #1..... 159.00

AMACO® Celedon Glazes

Mid/High Fire

Cat. No.	Description	Pint Liquid
* C-1	Obsidian.....	\$11.40
* C-10	Snow.....	11.40
* C-11	Mixing Clear.....	11.40
* C-20	Cobalt.....	11.40
* C-21	Sky.....	11.40
* C-22	Fog.....	11.40
* C-23	Ice.....	11.40
* C-27	Storm.....	11.40
* C-36	Iron.....	11.40
* C-40	Aqua.....	11.40
* C-41	Pear.....	11.40
* C-43	Wasabi.....	11.40
* C-47	Jade.....	11.40
* C-49	Rainforest.....	11.40
* C-50	Cherry Blossom.....	11.40
* C-53	Weeping Plum.....	11.40
* C-56	Lavender.....	11.40
* C-60	Marigold.....	11.40



Glazes 28

Foundations Opaque (Non-Toxic)

Prod. #	Description	Pint	Gal.
FN-001	White	\$12.15	\$70.00
FN-002	Yellow	12.15	70.00
FN-003	Orange	12.15	70.00
FN-004	Red	12.15	70.00
FN-005	Pink	12.15	70.00
FN-006	Blue	12.15	70.00
FN-007	Green	12.15	70.00
FN-008	Brown	12.15	70.00
FN-009	Black	12.15	70.00
FN-010	Tree Green	12.15	70.00
FN-011	Light Blue	12.15	
FN-012	Lavender	12.15	
FN-013	Light Yellow	12.15	
FN-014	Antique White	12.15	
FN-015	Brick Red	12.15	
FN-016	Harvest Orange	12.15	
FN-017	Purple	12.15	70.00
FN-018	Bright Blue	12.15	70.00
FN-019	Dark Blue	12.15	
FN-020	Medium Green	12.15	
FN-021	Olive Green	12.15	
FN-022	Tan	12.15	
FN-023	Cinnamon	12.15	
FN-024	Gray	12.15	
FN-025	Raspberry Whip	12.15	
FN-026	Salmon Mousse	12.15	
FN-027	Glade Green	12.15	
FN-028	Wisteria Purple	12.15	
FN-029	Rich Chocolate	12.15	
FN-030	Bing Cherry	12.15	
FN-031	Corn Flower Blue	12.15	
FN-032	Canton Jade	12.15	
FN-033	Mediterranean Teal	12.15	
FN-034	Big Sky Blue	12.15	
FN-035	Deep Red	12.15	
FN-036	Grape	12.15	
FN-037	Chartreuse	12.15	
FN-038	Sand	12.15	
FN-039	Bing Cherry	12.15	
FN-040	Pumpkin	12.15	
FN-041	Medium Blue	12.15	

Foundations Sheer (Non-Toxic)

Prod. #	Description	Pint
FN-201	Golden Clear	\$12.15
FN-202	Yadro	12.15
FN-203	Dry Champagne	12.15
FN-204	Mudpuddle Brown	12.15
FN-205	Saddle Tan	12.15
FN-206	Lemon Ice	12.15
FN-207	Orange Slice	12.15
FN-208	Crystal Coral	12.15
FN-209	Floral Pink	12.15
FN-210	Victorian Red	12.15
FN-211	Sheer Blue	12.15
FN-212	Blue Diamond	12.15
FN-213	Saffire Blue	12.15
FN-214	Pastel Jade	12.15
FN-215	Atzec Jade	12.15
FN-216	Sea Glass	12.15
FN-217	Evergreen Fir	12.15
FN-218	Green Sapphire	12.15
FN-219	Lustre Green	12.15
FN-220	Sooty Grey	12.15
FN-221	Milk Glass	12.15
FN-222	Indigo	12.15
FN-223	Amethyst	12.15
FN-224	Key Lime	12.15
FN-225	Watermelon	12.15

Jungle Gems™ Crystal Glazes (Non-Toxic)

Prod. #	Description	Pint
CG-707	Woodland Fantasy	\$18.25
CG-713	Peacock Green	18.25
CG-716	Pagoda Green	18.25
CG-717	Pistachio	18.25
CG-718	Blue Caprice	18.25
CG-722	Seawind	18.25
CG-750	Noel	18.25
CG-753	Sassy Orange	18.25
CG-756	Firecracker	18.25
CG-772	Sand Petal	18.25
CG-779	Black Opal	18.25
CG-780	Mystic Jade	18.25
CG-783	Strawberry Sundae	18.25
CG-785	Royal Fantasy	18.25
CG-786	Obsidian	18.25
CG-788	Dutch Enamelware	18.25
CG-793	Beach Pebbles	18.25
CG-795	Yadro Print	18.25
CG-798	Black Iris	18.25
CG-954	Wildfire	18.25
CG-958	Lagoon Blue	18.25
CG-961	Evergreen	18.25
CG-962	Blue Azure	18.25
CG-963	Lemon Lime	18.25
CG-964	Kaleidoscope	18.25
CG-965	Mocha Marble	18.25
CG-966	Tiger Lily	18.25
CG-967	Green Agate	18.25
CG-968	Peppermint Twist	18.25
CG-969	Floral Fantasy	18.25
CG-970	Masquerade	18.25
CG-971	Purple Cosmos	18.25
CG-972	Dragon's Breath	18.25
CG-973	Alligator	18.25
CG-974	Bloomin' Blue	18.25
CG-975	Sky Diamonds	18.25
CG-977	Ink Spot	18.25
CG-978	Artic Splash	18.25
CG-979	Meadow	18.25
CG-980	Coral Pull	18.25
CG-981	Fruity Freckles	18.25
CG-982	Mixed Melon	18.25
CG-983	Koi Pond	18.25
CG-984	Ladybug	18.25

Crystalites™ (Non-Toxic)

Prod. #	Description	Pint
S-2701	Peacock Eyes	\$18.25
S-2702	Northern Lights	18.25
S-2703	Berryberry Pie	18.25
S-2704	Plum Jelly	18.25
S-2708	Oriental Carmel	18.25
S-2709	Cappuccino Mint	18.25
S-2711	Tahiti Grape	18.25
S-2712	Monsoon Seas	18.25
S-2713	Buttercup Blue	18.25
S-2714	Herb Garden	18.25
S-2715	Spotted Kiwi	18.25
S-2716	Celestial Blue	18.25
S-2718	Cosmic Black	18.25
S-2719	Cranberry Burst	18.25
S-2723	Grape Divine	18.25
S-2724	Lotus Blossom	18.25
S-2725	Safari	18.25
S-2726	Cheetah	18.25
S-2727	Poppy Fields	18.25
S-2728	Poinsettia	18.25
S-2729	Citrus Splash	18.25
S-2731	Kaboom	18.25

Elements™ (Non-Toxic)

Prod. #	Description	Pint
EL-101	Oyster Shell	\$13.50
EL-102	Sandstorm	13.50
EL-103	Sea Spray	13.50
EL-105	River Birch	13.50
EL-106	Tidal Pool	13.50
EL-107	Amber Ash	13.50
EL-108	Jade Moss	13.50
EL-109	Blue Ridge	13.50
EL-110	Mudslide	13.50
EL-111	Ruby Creek	13.50
EL-112	Tornado Sky	13.50
EL-113	Spanish Moss	13.50
EL-116	Blue Stone	13.50
EL-117	Waterfall	13.50
EL-118	Blue Grotto	13.50
EL-119	Burnished Steel	13.50
EL-120	Black Ice	13.50
EL-121	Copper Adventurine	13.50
EL-122	Malachite	13.50
EL-123	Patina	13.50
EL-124	Stormy Blue	13.50
EL-125	Sahara Sands	13.50
EL-127	Rose Granite	13.50
EL-128	Wheat	13.50
EL-129	Slate	13.50
EL-130	Sea Green	13.50
EL-131	Turtle Shell	13.50
EL-132	Rust Red	13.50
EL-133	Autumn	13.50
EL-134	Mirror Blue	13.50

Elements Chunkies™ (Non-Toxic)

Prod. #	Description	Pint
EL-201	River Bottom	\$18.25
EL-202	Bark	18.25
EL-204	Glowing Embers	18.25
EL-205	Jade Pebble	18.25
EL-207	Gold Mine	18.25
EL-208	Moss Creek	18.25
EL-209	Night Sky	18.25
EL-211	Volcanic Glow	18.25

Classic Crackles™ (Non-Toxic)

Prod. #	Description	Pint
CC-101	Transparent Crackle	\$12.75
CC-102	White Crackle	12.75
CC-107	Green Tea	12.75
CC-108	China Sea	12.75

Non-Toxic Specialty Glazes (Non-Toxic)

Prod. #	Description	4 oz.	Pint
SG-201	Black Cobblestone	\$3.60	\$11.25
SG-202	White Cobblestone	3.60	11.25
SG-302	Snowfall	3.95	12.25

Pottery Cascades™ (Non-Toxic)

Prod. #	Description	4 oz.	Pint
PC-601	Clear Cascade	\$5.50	\$16.95
PC-602	White Cascade	5.50	16.95
PC-603	Amber Cascade	5.50	16.95
PC-604	Black Cascade	5.50	16.95

Raku (Non-Toxic)

Prod. #	Description	Pint
RK-100	Black Metallic	\$12.25
RK-101	Copper Metallic	12.25
RK-103	White Crackle	12.25
RK-104	Red	12.25
RK-105	Copper Penny	12.25
RK-106	Peacock Matte	12.25
RK-107	Oil Slick	12.25

Call us toll free 1.866.410.CLAY

Serving Schools and Studios Since 1939

29 Glazes Mayco®

Underglazes (Non-Toxic)

Prod. #	Description	2 oz.	Pint	Gal.
UG-1	Kings Blue	\$3.75	\$16.85	
UG-2	Sea Blue	3.75	16.85	
UG-3	Baby Blue	3.75	16.85	
UG-10	Crimson	3.75	16.85	
UG-19	Electra Blue	3.75	16.85	
UG-21	Leaf Green	3.75	16.85	
UG-22	Spring Green	3.75	16.85	
UG-30	Sand	3.75	16.85	
UG-31	Chocolate	3.75	16.85	
UG-32	Cocoa	3.75	16.85	
UG-34	Chestnut Brown	3.75	16.85	
UG-37	Suntan	3.75	16.85	
UG-42	Light Yellow	3.75	16.85	
UG-46	Bright Yellow	3.75	16.85	
UG-50	Jet Black	3.75	16.85	84.00
UG-51	China White	3.75	16.85	84.00
UG-53	Silver Grey	3.75	16.85	
UG-57	Spice Brown	3.75	16.85	
UG-58	Harvest Gold	3.75	16.85	
UG-67	Ivory	3.75	16.85	
UG-68	Apple Green	3.75	16.85	
UG-72	Wedgewood Blue	3.75	16.85	
UG-82	Tucson Turquoise	3.75	16.85	
UG-85	Orange Sorbet	3.75	16.85	
UG-87	Regal Purple	3.75	16.85	
UG-90	Green Mist	3.75	16.85	
UG-91	True Teal	3.75	16.85	
UG-92	Lilac	3.75	16.85	
UG-93	Wild Violet	3.75	16.85	
UG-94	Pansy Purple	3.75	16.85	
UG-97	Bright Blue	3.75	16.85	
UG-100	Terra Cotta	3.75	16.85	
UG-146	Pink Pink	3.75	16.85	
UG-198	Dark Grey	3.75	16.85	
UG-203	Squash Yellow	3.75	16.85	
UG-204	Orange	3.75	16.85	
UG-206	Fire Engine Red	3.75	16.85	
UG-207	Flame Red	3.75	16.85	
UG-208	Dragon Red	3.75	16.85	
UG-209	Jade	3.75	16.85	
UG-210	Forest Green	3.75	16.85	
UG-211	Olive	3.75	16.85	
UG-213	Cinnamon	3.75	16.85	
UG-214	Peachy Pink	3.75	16.85	

Stroke & Coat

Prod. #	Description	4 oz.	Pint
SC-88	Tu Tu Tango	\$3.65	\$17.75
SC-89	Cutie Pie Coral	3.65	17.75
SC-90	Elephant Ears	3.65	17.75
SC-91	Seabreeze	3.65	17.75
SC-92	Cafe Ole	3.65	17.75
SC-93	Honeydew List	3.65	17.75
SC-94	Curry Around	3.65	17.75
SC-95	Pinky Swear	3.65	17.75

Stoneware Clear (Non-Toxic) Cone 6 to Cone 10

Prod. #	Description	Pint	Gal.
SW-001	Stoneware Clear (Liquid)	\$10.75	\$37.00
SW-002	Stoneware Matte Clear (Liquid)	10.75	49.00
SW-003	Stoneware Crackle Matte Clear (Liquid)	10.75	49.00

Non-Toxic Clear Glazes (Non-Toxic)

Prod. #	Description
S-2101	Crystal Clear Brushing Pint \$8.25, Gal. \$29.00 3 Gal. \$72.00
C-300	Matte Transparent... 4 oz. \$2.50; Pint \$7.95; Gal. \$27.50
S-2000	Crystal Clear Dipping Gal. \$27.50; 5 Gal. \$114.00
NT-CLR	Clear One Dipping 3 Gal. \$63.00

Stroke & Coat® (Non-Toxic) (* Available in Gallons) ~ Gallon ... \$120.95

Prod. #	Description	2 oz.	Pint
SC-1	Pink-A-Boo	\$3.65	\$17.95
SC-2	Melon-choly	3.65	17.95
SC-3	Wine About It	3.65	17.95
SC-4*	Salsa	3.65	17.95
SC-5	Tiger Tail	3.65	17.95
SC-6*	Sunkissed	3.65	17.95
SC-7	Leapin' Lizard	3.65	17.95
SC-8*	Just Froggy	3.65	17.95
SC-9	Jaded	3.65	17.95
SC-10	Teal Next Time	3.65	17.95
SC-11*	Blue Yonder	3.65	17.95
SC-12*	Moody Blue	3.65	17.95
SC-13	Grapel	3.65	17.95
SC-14	Java Bean	3.65	17.95
SC-15*	Tuxedo	3.65	17.95
SC-16*	Cotton Tail	3.65	17.95
SC-17	Cheeky Pinky	3.65	17.95
SC-18	Rosey Posey	3.65	17.95
SC-20	Birthday Suit	3.65	17.95
SC-22	Carrot Top	3.65	17.95
SC-23	Jack O' Lantern	3.65	17.95
SC-24*	Dandelion	3.65	17.95
SC-25	Crackerjack Brown	3.65	17.95
SC-26	Green Thumb	3.65	17.95
SC-27*	Sour Apple	3.65	17.95
SC-28	Blue Isle	3.65	17.95
SC-29	Blue Grass	3.65	17.95
SC-30	Blue Dawn	3.65	17.95
SC-31*	The Blues	3.65	17.95
SC-32	Bluebeard	3.65	17.95
SC-33	Fruit of the Vine	3.65	17.95
SC-34	Down to Earth	3.65	17.95
SC-35	Gray Hare	3.65	17.95
SC-36	Irish Luck	3.65	17.95
SC-37	Ivory Tower	3.65	17.95
SC-39	Army Surplus	3.65	17.95
SC-40	Blueberry Hill	3.65	17.95
SC-41	Brown Cow	3.65	17.95
SC-42	Butter Me Up	3.65	17.95
SC-43	Lettuce Alone	3.65	17.95
SC-45	My Blue Heaven	3.65	17.95
SC-46	Rawhide	3.65	17.95
SC-48	Camel Back	3.65	17.95
SC-50	Orange Ya Happy	3.65	17.95
SC-51	Poo Bear	3.65	17.95
SC-52	Toad-ily Green	3.65	17.95
SC-53	Purple Haze	3.65	17.95
SC-54	Vanilla Dip	3.65	17.95
SC-55	Yella Bout It	3.65	17.95
SC-58	501 Blues	3.65	17.95
SC-60	Silver Lining	3.65	17.95
SC-63	Popeye's Favorite	3.65	17.95
SC-65	Peri-Twinkle	3.65	17.95
SC-70	Pink-A-Dot	3.65	17.95
SC-71	Purple-licious	3.65	17.95
SC-72	Grape Jelly	3.65	17.95
SC-73*	Candy Apple Red	3.65	17.95
SC-74*	Hot Tamale	3.65	17.95
SC-75*	Orange-A-Peel	3.65	17.95
SC-76*	Cara-Bein Blue	3.65	17.95
SC-77	Glo Worm	3.65	17.95
SC-78	Lime Light	3.65	17.95
SC-79	It's Sage	3.65	17.95
SC-80	Basketball	3.65	17.95
SC-81	Cinnamon Stix	3.65	17.95
SC-82	Tuscan Red	3.65	17.95
SC-83	Tip Taupe	3.65	17.95
SC-84	Dee John	3.65	17.95
SC-85	Orkid	3.65	17.95
SC-86	Old Lace	3.65	17.95
SC-87	Ruby Slippers	3.65	17.95

Speckled Stroke & Coat® (Non-Toxic)

Prod. #	Description	2 oz.	Pint
SP-201	Speckled Pink-A-Boo	\$3.85	\$19.75
SP-203	Speckled Wine About It	3.85	19.75
SP-205	Speckled Tiger Tail	3.85	19.75
SP-206	Speckled Sunkissed	3.85	19.75
SP-210	Speckled Teal Next Time	3.85	19.75
SP-211	Speckled Blue Yonder	3.85	19.75
SP-212	Speckled Moody Blue	3.85	19.75
SP-213	Speckled Grapel	3.85	19.75
SP-215	Speckled Tuxedo	3.85	19.75
SP-216	Speckled Cotton Tail	3.85	19.75
SP-223	Speckled Jack O' Lantern	3.85	19.75
SP-226	Speckled Green Thumb	3.85	19.75
SP-227	Speckled Sour Apple	3.85	19.75
SP-231	Speckled The Blues	3.85	19.75
SP-241	Speckled Brown Cow	3.85	19.75
SP-245	Speckled My Blue Heaven	3.85	19.75
SP-253	Speckled Purple Haze	3.85	19.75
SP-254	Speckled Vanilla Dip	3.85	19.75
SP-260	Speckled Silver Lining	3.85	19.75
SP-270	Speckled Pink-A-Dot	3.85	19.75
SP-274	Speckled Hot Tamale	3.85	19.75
SP-275	Speckled Orange-A-Peel	3.85	19.75
SP-279	Speckled It's Sage	3.85	19.75

New Additions To The Mayco Stoneware Line Are Available. See Color Inserts. Call For Pricing.

**Stoneware (Non-Toxic) Cone 6 to Cone 10
(Available in 25 lb. dry ~ Call for price)**

Prod. #	Description	Pint
SW-100	Blue Surf	\$10.95
SW-101	Stoned Denim	10.95
SW-102	Silver Sage	10.95
SW-103	Sisal	10.95
SW-104	Black Walnut	10.95
SW-105	Frost Blue	10.95
SW-106	Alabaster	10.95
SW-107	Dunes	10.95
SW-108	Green Tea	10.95
SW-109	Capri Blue	10.95
SW-110	Oyster	10.95
SW-111	Wrought Iron	10.95
SW-112	Tiger's Eye	10.95
SW-113	Speckled Plum	12.60
SW-115	Midnight Rain	14.25
SW-116	Robin's Egg	14.25
SW-117	Honeycomb	14.25
SW-118	Sea Salt	14.25
SW-119	Cinnabar	12.60
SW-120	Northern Woods	10.95
SW-121	Smoke	10.95
SW-122	Maycoshino	10.95
SW-123	Sapphire	14.25
SW-124	Matte Maycoshino	14.25
SW-125	Purple Mint	14.25
SW-126	Polished Pebbles	10.95
SW-127	Olivine	10.95

Stoneware Ice (Non-Toxic) Cone 6 to Cone 10

Prod. #	Description	Pint
SW-201	Turquoise	\$10.95
SW-202	Pistachio	10.95
SW-203	Root Beer	10.95
SW-204	Amber Topaz	10.95
SW-205	Coral	14.25
SW-206	Melon	14.25
SW-207	Chambray	14.25
SW-208	Camel	14.25
SW-209	Charcoal	14.25
SW-210	Emerald	14.25
SW-211	Glacier Blue	12.60
SW-212	Peacock	10.95

KEMPER TOOLS®

Double "O" Rib, 12"

This rib is hand formed and finished from imported hardwood and is used for cutting, slicing, shaping and smoothing soft clay.



RBOO, 12" \$9.19

Throwing Sticks

Patterned from the ancient Japanese egote, these throwing sticks aid in shaping and compressing deep and narrow necked wheel-thrown pieces. These throwing sticks are made in two sizes of fine imported hardwood and are polished to a satin-smooth finish.



TS1, 12-1/2" \$11.89



TS2, 12-1/2" \$11.89

Throwing Stick 11-1/2"

Aluminum Caliper

AL8 Aluminum Caliper 8" \$7.39

AL10 Aluminum Caliper 10" \$8.49

AL12 Aluminum Caliper 12" \$10.09

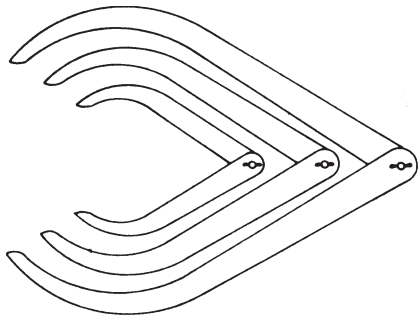

CLS Clay Lift Set

\$8.29

The Clay Lift Set has two double-ended tools with sharpened stainless steel spoons contoured for easy insertion, lifting, and removal from moist clay. Instructions are also included with each set. This set makes possible the creation of many new decorating patterns and varied effects previously difficult to obtain, such as bird feathers, flower petals, and fish scales. The spoons are firmly held by solid brass ferrules to smooth wooden handles. Each tool is approximately 7" long.

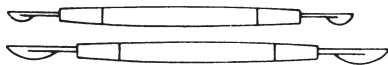

DTA Dipping Tong

\$11.49

Dipping tongs are used to dip ceramic pieces directly into the glaze. They are made from heavy plated steel and feature four sharp gripping points that make minimal contact with the piece being dipped. The tongs are about 10" long.

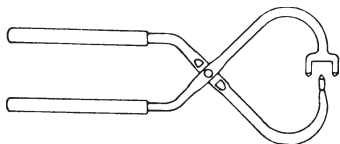

F96 Fettling Knife (soft) \$6.99

F97 Fettling Knife (hard) \$6.99



K35 Wire Clay Cutter \$3.09

K36 Nylon Clay Cutter \$2.99

Clay Cutters are used for slicing and cutting lump clay. They also cut pots and other items from the throwing head of the potter's wheel. Hardwood 3" toggle handles are firmly fastened to approximately 18" of fine quality stainless steel for the K35.



Finish Rubbers

\$3.99

These finish rubbers are molded from pliable rubber in two kidney shapes and two grades of resiliency. They are used for smoothing, shaping and finishing pottery pieces.

FRSS.....Small, soft 3-1/8"

FRSM.....Small, hard, 3-1/8"

FRSO.....Large, soft, 4-1/4"

FRH.....Large, hard, 4-1/4"

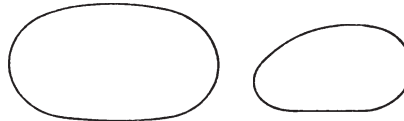

Loop Tools

\$3.99

Loop Tools are used to removed controlled amounts and shapes of clay from wheel-thrown pieces and clay sculpture pieces. The shaped cutting heads are made from heavy stainless steel ribbon with sharpened edges. Rugged hardwood handles provide a sure grip and allow easy manipulation of these tools in wet clay.



LT1 1/2" wide cutting head



LT2 3/4"



LT3 1"

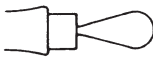

LT4 1/2"

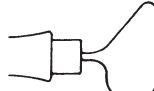

LT5 1 1/4"



LT6 1 1/4"



LT7 1 1/8"

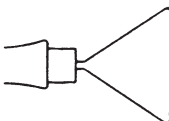

LT8 1 3/4"

Tools 30

K45 Klay Gun

\$16.49

This tool is used to force soft clay through various shaped openings in an assortment of interchangeable discs. The extruded clay shapes can be used for an almost limitless number of decorative effects such as hair, grass, flower stamens, rope, logs, bricks, vines and stems. The Klay Gun is furnished with a set of 19 discs that are formed to allow flush cutoff of the extruded clay. It is constructed of sturdy die cast zinc alloy and is about 4" long.

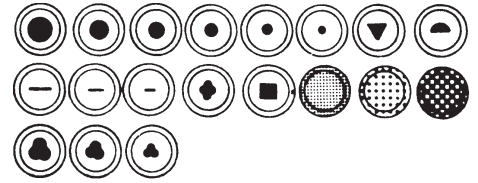
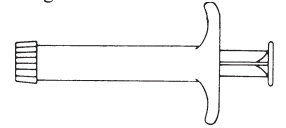

IKEG Klay Extruder Gun

This Calk gun style extruder has a 20 inch long barrel, 2 inches in diameter. Fast action trigger, easy loading, and includes an 1/8", 1/4", 1/2" coil dies and one blank die.

Price.....\$55.99

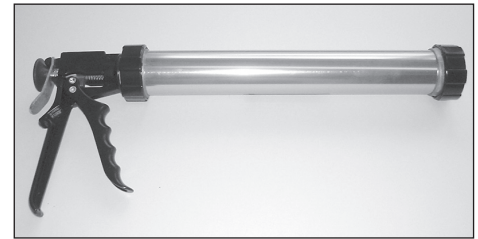

Hole Cutters

Hole Cutters provide an easy method for cutting clean holes in wet thick-wall greenware and wheel-thrown items. All four sizes can be used to achieve a variety of designs. The cutting tubes are sharpened polished brass and are set in smooth hardwood handles.

HC1 3/16" Hole Cutter.....\$3.59

HC1A 1/4" Hole Cutter.....\$3.98

HC2 5/16" Hole Cutter.....\$3.89

HC3 1/2" Hole Cutter.....\$4.39

HC4 7/8" Hole Cutter.....\$9.49



Basic Tool, 7-1/2"

This is an all-wood tool that is sharp and pointed on one end and square and flat on the other. It is used for modeling in soft clay, for cleaning hard-to-reach areas on greenware and light sgraffito work.

BAS, 7-1/2" \$1.59



ROLLING PINS

Solid Maple Rolling Pins (Non-bearing handles)

18" Solid Maple..... \$30.00

24" Solid Maple..... \$35.00

30" Solid Maple..... \$42.00

Call us toll free 1.866.410.CLAY

Serving Schools and Studios Since 1939

31 Tools

Pot Lifter

These Pot Lifts provide an easy method for removing pottery items from the throwing wheel without damage. They are made from rust-free, high-strength aircraft aluminum alloy.

- PL1 Pot Lift (pair) 6" wide \$11.99
- PL2 Pot Lift (pair) 5" wide \$10.49
- PL3 Pot Lift (pair) 4" wide \$9.99

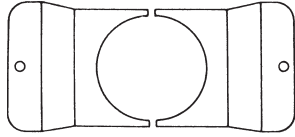

PNH Potter's Needle \$1.99

This tool has a heavy sharp needle set in a 1/2-inch diameter hardwood handle. Potters use this tool to cut through and remove the uneven top edge of wheel-thrown items. Tool is 5" long.

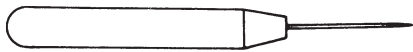

PRO Tool \$2.59

This is our heaviest needle tool. The large sharp needle is firmly set in an aluminum handle which is finely textured to provide a firm grip for wet hands. The Pro Tool may be used to cut heavy clay strips, to cut designs in clay, and to put holes in salt shakers. 6-5/8" long.



PCN Potter's Cut-Off Needle \$1.09

A necessity for all potters, this thin needle set in a hardwood handle is used to cut through and remove the uneven top edge of thrown items. The needle makes a clean smooth cut with a minimum of drag.



Scrapers

Scrapers are used for shaping, smoothing and trimming pottery shapes. The steel scrapers are made from thin flexible spring steel.

- S1 Steel, 4-5/8" \$2.29
- S3 Steel, 4" \$2.29
- S4 Steel, 3-7/8" \$2.49
- SA4 Aluminum \$2.29
- S10 Steel, 3-3/8" \$3.09
- S11S Steel \$3.79
- S12 Steel, 6" \$3.69

Potter's Ribs

These ribs are made from smooth-finished, imported hardwood. They employ the basic shapes required for opening, shaping, curving, smoothing and trimming wet clay on the potter's wheel. Sizes range from 3-1/2" to 5-1/2" long.

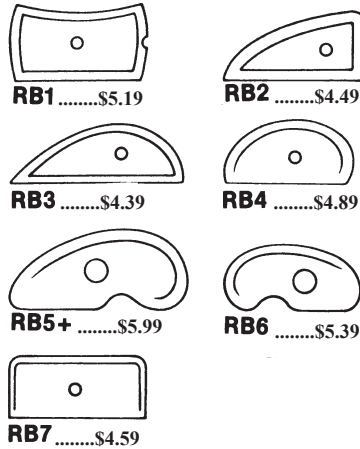

Turning Tools \$11.69

Turning tools are used by potters to accurately shape, contour, and trim clay and plaster forms on the wheel. The heavy steel heads are brazed to steel shafts, plated, and firmly set into smooth hardwood handles. TT4 is a right-hand half moon; TT5 is a left-hand half moon. All turning tools are approximately 9-3/4" long.

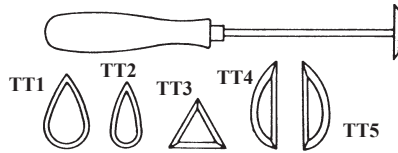

SLT Scratch and Lift Tool \$5.19

For both sgraffito (scratch) work and clay lifting. Working end is a steel scratch knife, handle is smooth plastic. Length is 7-1/2".

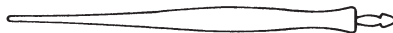

WLS Wire Loop Sgraffito \$3.79

The small wire loops on each end of this tool provide a method of sgraffito in which variations of line width can be made within a single stroke. The furrow created by the loops is smooth and does not exhibit the flakiness usually associated with other sgraffito methods.



WS Wire Stylus \$4.39

The Wire Stylus is a versatile tool for incising greenware. A small wire loop, firmly set in a hardwood handle creates various size furrows, depending on the angle of the point.

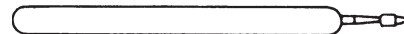

CUB Cleanup Brush \$4.49

The double-ended cleanup brush is used to clean small, delicate areas in greenware.

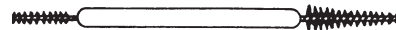

AB Lace Tool \$3.19

Heavy, sharp needle; curved, pointed stainless steel blade; 5/16" dia. handle, 6-1/2" overall length.

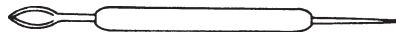

JA Series Modeling Tools \$1.99 each

Recommended for beginner's. These smooth, hand-crafted modeling tools are made from the finest quality boxwood.

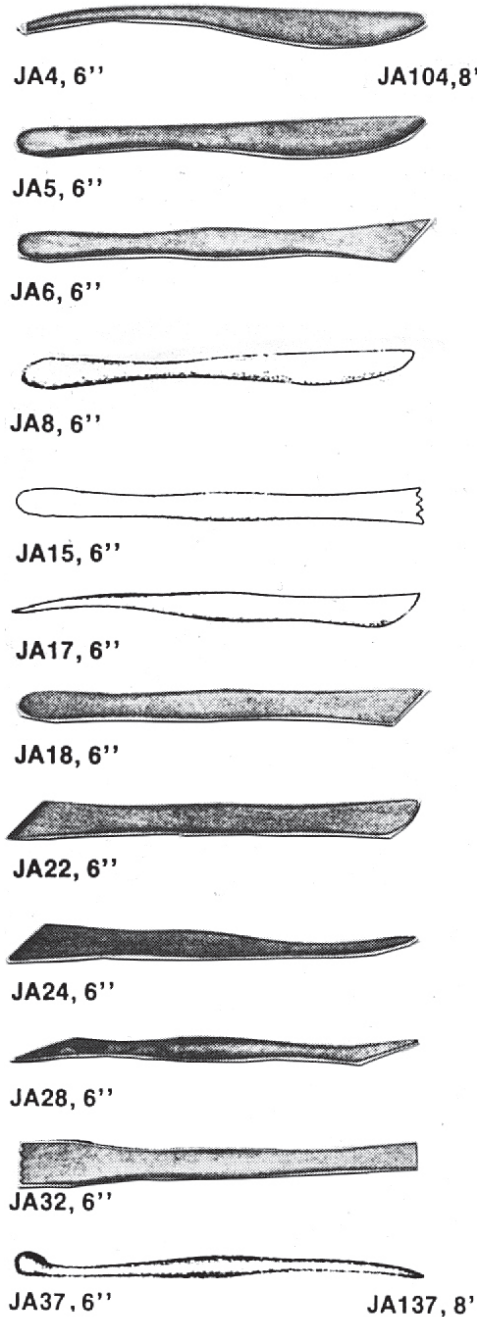

JAS Series Sculpting Set \$16.79

(JA4, 5, 6, 8, 15, 17, 18, 22, 24, 28, 32, 37)
This set contains twelve 6 inch imported wood modeling tools for cutting, slicing, smoothing, contouring and pattern decorating in soft clay.



WT Series Wood Modeling Tools

This series of wood tools offers a wide variety of shapes and contours for basic clay modeling. They are used for cutting, slicing, smoothing, contouring and pattern decorating in soft clay. They are made from imported hardwood and have a satin smooth finish. Rigid manufacturing processes assure consistent quality and form.

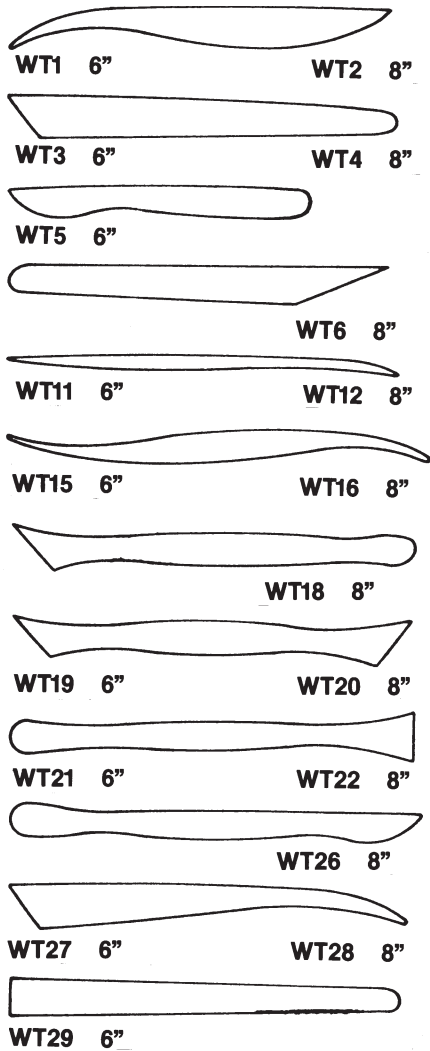

No. WT

1,3,19,21,27,29	\$3.69
2,4,5,6,15,18,20,26,28,22	4.49
11	3.69
12	4.49
16	4.29

10 Inch Wood Modeling Tools \$6.29

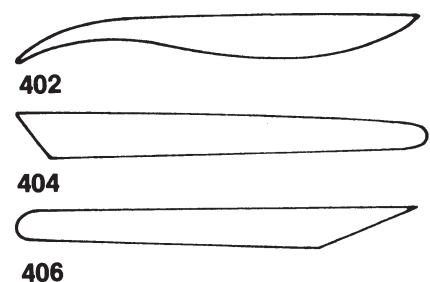

Call us toll free 1.866.410.CLAY

6 Inch Wire End Tools

Wire end tools are used to remove controlled amounts and shapes of clay. These 6 inch tools are suitable for light cutting and slicing. The ends are made from high-strength music wire and are firmly attached to the hardwood handles with brass ferrules.

Per Tool.....\$4.39
 DSS Series Sculpting Set 5 tools.....\$19.69

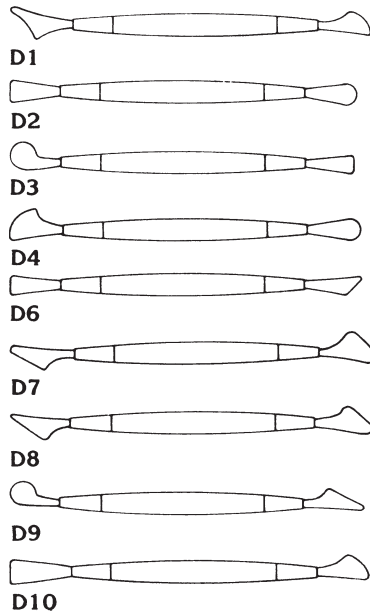

RSS Series Sculpting Set

(R1 thru R5)

This set contains five 6 inch double ended ribbon tools with a wide variety of shapes used for light cutting and shaping. Designed with the student in mind as well as the experienced sculptor. The set is packaged in a reusable vinyl pouch that can easily be rolled up and stuffed in a pocket.

RSS Sculpting Set.....\$16.99
 Per Tool.....\$3.99

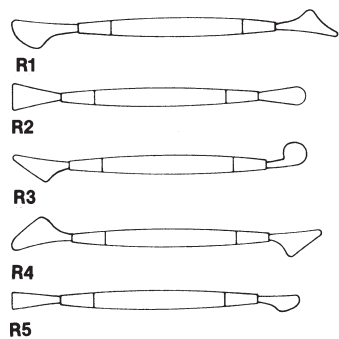

Cut-Out-Tool

These tools are used to cut through wet clay to make cut-out designs and openings in slab clay and clay vessels. The COR has a thin double-edged steel blade for thin-wall greenware and delicate work. The COH has a heavier, sharp triangular stainless steel blade that is designed for heavy, thick-wall greenware and pottery.

COR Cut-Out Tool 4-1/2".....\$3.89

COH Cut-Out Tool Heavy Duty 5-3/4".....\$3.79

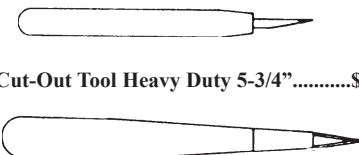

8RSS Series Sculpting Set

This set contains five 8 inch double ended ribbon tools with a wide variety of shapes for medium duty clay cutting, shaping, and slicing. Designed with the student in mind as well as the experienced potter and sculptor. The set is packaged in a reusable vinyl pouch that can easily be rolled up and stuffed in a pocket.

8RSS Set.....\$21.49
 Per Tool\$4.89

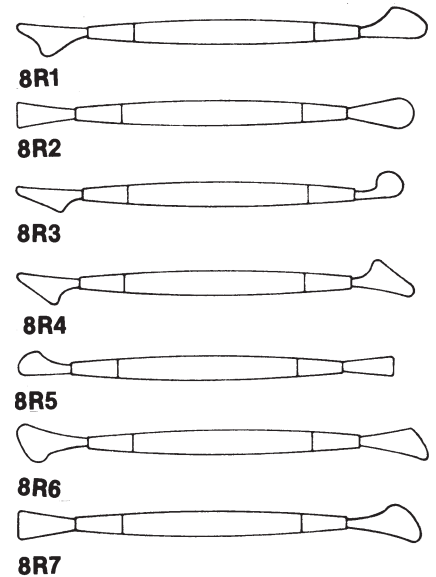

Special Ribbon Tools

\$5.29

Designed for medium duty pottery and sculpture work, these tools have sharpened stainless steel ribbon ends which are attached to hardwood handles with heavy brass ferrules. 7" long.

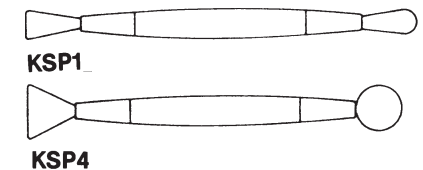

STH Sculptor's Thumb

\$7.99

This is a compact hand-fitting sculpture tool that duplicates thumb and finger strokes without abrasive wear on the sculptor's hands, fingers, and thumbs. The Sculptor's Thumb is made from imported hardwood and is 5" long.



Lid Master

Make a lid for any pot. Take one measurement and you have its opposite immediately. A traditional wood workers' tool modified and improved for the potter.

Lid Master 11" Capacity.....\$14.95
 Lid Master Large 20" Capacity.....\$27.95

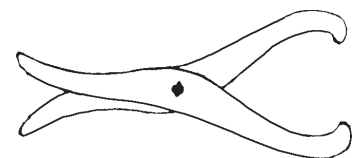

Serving Schools and Studios Since 1939

33 Tools

Wire And Wood Tools

Wire and Wood Tools are combinations of wood modeling tools and wire tools. The 5 inch and 6 inch Wire and Wood Tools are used for delicate clay removal, modeling and shaping. They are made with plated high strength music wire, brass ferrules and imported hardwood.

5 Inch Wire and Wood Tools.....\$5.49



W21



W22



W23



W24



W25



W26

6 Inch Wire and Wood Tools.....\$7.09



W1a



W1c



W1d



W2a



W3e



W5

Ceramic Tool Kit CTK7 \$26.99

The seven most practical and popular Kemper tools for ceramists. Good for beginners; equally useful to advanced and professional level ceramists. Ideal for classroom use. The complete tool kit contains one each: Wire Loop Sgraffito, Cleanup Tool, Cut-out Tool, Palette Knife, Lace Tool, Sabre Saw, Salt and Pepper Drill. Kit is packaged in reusable plastic tray.



Serving Schools and Studios Since 1939

8 Inch Double Wire End Tools \$6.39

This assortment of 8 inch tools provides the sculptor and potter with a series of shapes designed for medium duty cutting and slicing of clay. The wire ends are formed from high-strength stainless steel and are firmly attached to hardwood handles with brass ferrules.

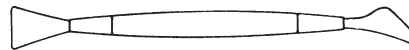

8A1

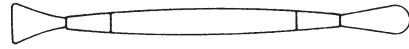

8B2

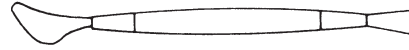

8C3

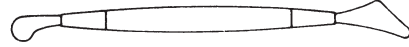

8D4

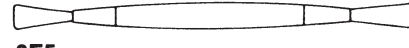

8E5

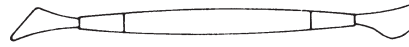

8G7

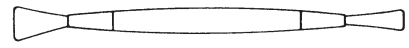

8H8

STB Slip Trailing Bottle \$3.89

Slip Trailing Bottles are used by potters and ceramists to flow casting slips, glazes, and engobes onto ceramic pieces in raised decorative designs. The Kemper Slip Trailing Bottle is supplied with a round spout, a ribbon spout, and caps for both spouts. The large capacity polyethylene bottles holds 4 ounces and is easy to hold and squeeze.

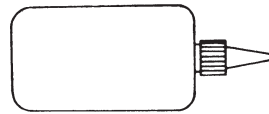

DBSS Double Ball Stylus Tool \$3.09

Excellent for sgraffito, with variations according to size of ball end. Each tool has a coarse and fine ball of stainless steel, treated for hardness and set in a smooth hardwood handle. The furrow made by the Double Ball Stylus does not create flaking or collapsing of the sgraffito line. 5-1/2" long.

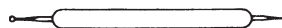

MRS Mini Ribbon Sculpting Tools, 5-1/2" Set \$16.89 Per Tool \$3.09

These miniature sculpting tools are made of fine ribbon steel heat treated for maximum strength and are just the answer for your fine sculpting, detailing, and trimming requirements. Firmly set in a 1/4-inch diameter by 5 inch aluminum handle, these tools are ideal for working with clay, greenware, wax, bread dough, plaster or any other modeling medium.



MRS-1
MRS-2
MRS-3
MRS-4
MRS-5
MRS-6

K33L Spongette 13" \$4.19

Sponges are used for cleaning, smoothing, and decorating greenware and pottery. The Spongette Tool features a soft cellulose sponge mounted on a convenient handle. The K33L is designed especially for working in deep vessels.



SPG Sponge Holder

In order to reach the bottom and inside walls of some ceramic pieces, it is sometimes desirable to have a sponge on the end of a long handle. This Sponge Holder consists of a hard wooden handle, special attaching screw and cup washer to firmly hold your favorite sponge. Gouges in the clay workpiece are practically eliminated because the design causes the sponge to surround the metal parts of the holder. The Sponge Holder is approximately 13" long without sponge. (The Sponge is included with the Sponge Holder.)

SPG Sponge Holder.....\$5.39
SPR Replacement Sponge.....\$1.25

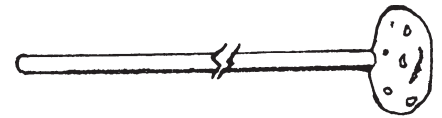

PTK Pottery Tool Kit \$20.99

All the basic pottery tools required for the professional as well as the beginner. The Kemper PTK contains: Loop Tool, Ribbon Tool, Potter's Rib, Needle Tool, Wood Modeling Tool, Sponge, Scraper, Wire Clay Cutter. Kit is packaged in reusable, clear vinyl bag with pockets for each tool.

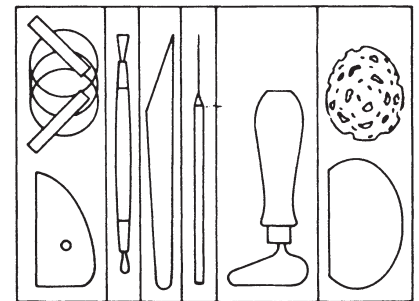

Budget PTK-9 With Fettling Knife.....14.99

Raku Tongs

These long-handled tongs are made from rust-free plated steel and are used to safely handle Raku ware without danger of burns to the potter. The jaws are solid and strong yet, can gently grip both large and small Raku pieces. Because the handles are tubular the tongs are both lightweight and strong.

RK45 Raku Tongs 31-1/2" Teeth.....\$56.99
RK 37 Raku Tongs 41" Toothless.....\$56.99

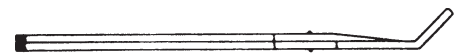

Disposable Surgical Scalpel \$2.99

Perfect for cutting out designs and shapes in moist clay. Surgically sharp, plastic handle, 5 1/2" long.



Visit our website at www.columbusclay.com

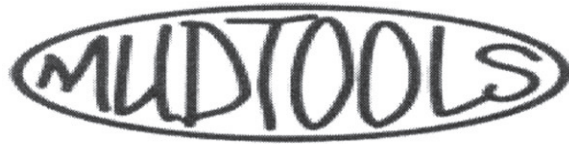

Please see www.columbusclay.com for pictures and details.

Flexible Ribs \$7.00 Each

Red	Yellow	Green	Blue
0	0	0	0
1	1	1	1
2	2	2	2
3	3	3	3
4	4	4	4
5	5	5	5

Small Bowl Flexible Ribs \$8.00 Each

SBR	SBY	SBG	SBB
-----	-----	-----	-----

Stainless Steel and Specialty Ribs

Regular Rib Shapes \$7.00	Paisley & Long Scrapers \$7.00	Specialty Ribs \$10.00	Large Specialty Ribs \$14.00
SS0	SSP	SSH015	SSXL
SS1	SSP18	HAX tool pk-2	SSXL10
SS2	SSP24		Large Bowl Rib Yellow
SS4	SSL		Large Bowl Rib Green
SS5	SSL12		Small Platter Rib
	SSL18		
	SSL24		Large Platter Rib \$16.00

Wire Tools

Mudwire Two Handled Cutoff Tool \$7.00	Mudcutter with Straight Wire \$35.00
Mudwire Curly Wire \$8.00	MC Replacement Wires Straight Pk-3 \$9.00
Mudwire Heavy Duty \$8.00	MC Replacement Wires Curly Pk-3 \$15.00
	Carving Bow with Curly Wire \$35.00
Wood Clay Paddle \$40.00	CB Replacement Wires Straight Pk-3 \$9.00
Bulls Tongue \$20.00	CB Replacement Wires Curly Pk-3 \$15.00

Specialty Mud Tools

Mud sponge \$5.00	The Bump Altering Tool \$24.00
	The Bump Altering Tool Curved \$24.00
Shredder Small \$8.00	The Baby Bump \$18.00
Shredder Replacement Blades Pk-2 \$6.00	Mudshark \$8.00
Shredder Conical Shape \$10.00	The Drag Tool \$20.00
Shredder Flat Shape \$10.00	
Zipper Bridge & Dye Kit \$250.00	

35 Tools

Plaster Tools

- Mold Maker Knife, 4" blade**
MM4.....\$28.00
Perforated Steel Plaster Rasps
#91 6-1/2".....\$13.00
#92 7-1/2".....\$15.00

Plaster Modeling Tools

Steel Plaster and Modeling Tools are made of the finest steel, beautifully designed, expertly finished. Spatulas are super-flexible .
184 9".....\$28.00



Shimpo Banding Wheels

Shimpo continues to offer the ideal in banding wheels which create a solid, steady, and reliable surface needed especially when applying delicate and fine touches to your work.

Shimpo Banding Wheels are favored by potters for their:

- * Heavy-duty construction
- * Smooth, precise rotation
- * Ball-bearing engineering (A,C,D)
- * Point socket rotation (B)
- * Concentric circles on wheel head
- * Rust resistant finish.

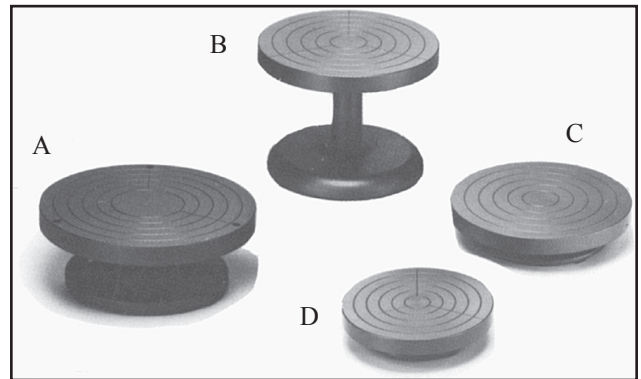

Key	Model	Table Diameter	Height	List Price	Weight	Ship Wt.
A	BW-30M	11-3/4"	4-3/4"	\$110.00	26 lbs.	28 lbs.
B	BW-25H	9-7/8"	7-1/2"	95.00	16 lbs.	19 lbs.
C	BW-25L	9-7/8"	2-1/4"	84.00	12 lbs.	15 lbs.
D	BW-22L	8-3/4"	2-1/4"	62.00	11 lbs.	13 lbs.
E	BW-18L	7"	2-1/4"	51.00	7 lbs.	9 lbs.



Amaco #5 Basic Banding Wheel

Good basic economical banding wheel. All Aluminum, perfect for modeling, finishing or decorating, the 7" wheel head is marked with concentric circles. Can be used portable or bolted to a table top. Grooved wheel shank accommodates a small round belt for mechanization.

Amaco #5 Banding Wheel \$34.95

Tools 36

Glaze Mixer

A great tool for mixing larger quantities of liquid glaze, engobes, slip, or anything that requires mixing. To operate, this mixer requires a 1/2" capacity variable speed drill.

Price.....\$37.95

New Mini Glaze Mixer (fits in pint jar)..... 27.00

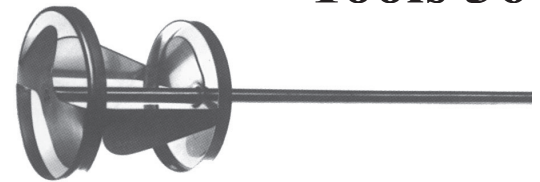

Lab Sieves

Used to screen glazes after mixing and before application to make sure all dry materials are well blended and homogenous. This sieve fits conveniently over a 5 gallon pail. The mesh number indicates holes per square inch.

30, 40, 60, 80, and 100 mesh available.....each \$41.95

Grinding Media for Ball Mills

Made of high density highly durable alumina porcelain to assure thorough grinding and mixing of glazes. Ball mills should be half full of grinding media for proper milling.

1 lb\$2.25

Plastic Pint Jar with Lid

Perfect for storing dry or liquid materials such as glazes, engobes, stains, raw materials. Resistant to cracking and warping.

1 Pint Jar with Lid.....\$2.50

Respirators 3M 8210

A light weight disposable dust mask with rubber straps, good to wear while handling respirable dusts such as silica, manganese, lead, and other clay related dusts. N95 approved.

Single Mask.....\$2.00

Box of 20 Masks.....\$36.95

AMACO Canvas Covered Wedging Board

A portable work surface for wedging and rolling clay. Ideal for moving and storing hand built projects. The absorbent canvas top for water-based clays prevents work from sticking to work the surface.

10"x10" Wedging Board.....\$13.95

AMACO Hydrometer for Specific Gravity.....\$33.95

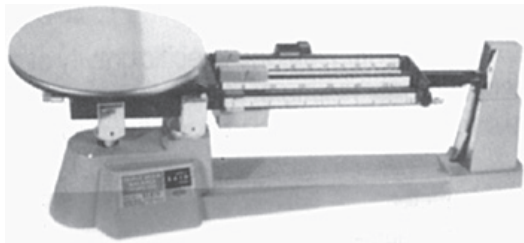

OHAUS MODEL 760 SCALE

The most versatile of all scales. It features the additional undivided tare beam which makes it possible to counterbalance any container up to 180 grams without extra compensation for the weight of container used. It has a six inch stainless steel plate.

MODEL 760 g.....\$225.00

Weight Set.....45.00

Scoop, Plastic.....20.00

Scoop, Stainless Steel.....75.00

Ship Wt. 8 lbs.

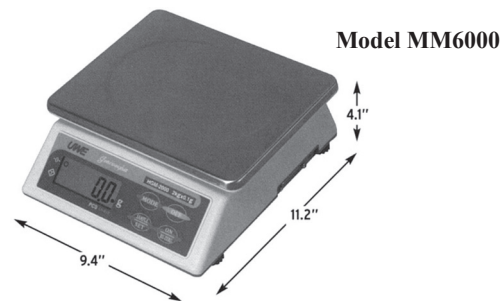

Model MM6000

DIGITAL MM-6000

Capacity: 6000 gm (13 lb.)

Accuracy: +/- 1 gram

Plater Size: 5" x 8"

Features: Low profile compact size, simple weighing scale suitable for shop, office and factory applications, light weight, totally portable strong ABS housing structure and platter provides years of trouble free operation simple and user friendly design, only minimum maintenance required.

Price.....\$189.95

DIGITAL MM-600

Capacity: 600 gm (1 lb. 5oz.)

Accuracy: +/- .1 gram

Plater Size: 5.25" x 6.25"

Features: Low profile compact size portable scale, built in weighing, counting and percentage checking function for various applications, equipped with power on zero tracking, re-zero, full tare range, auto calibration, power saving function user friendly operation, minimum maintenance required.

Price.....\$189.95

37 Tools

Brushes

REFLECTIONS Columbus Clay Brand Artist Series Brushes.

All acrylic handles for long life, natural bristles and extra long length for easy application for your glaze. Overall length 8 inches.

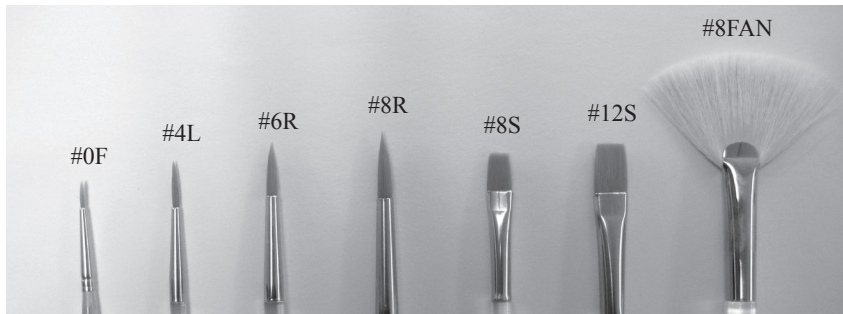

RB-100 #0 Fine Detail.....	\$5.50
RB-104 #4 Liner Brush.....	\$5.50
RB-116 #6 Round.....	\$6.60
RB-118 #8 Round.....	\$8.80
RB-108 #8 Shader.....	\$7.45
RB-112 #12 Shader.....	\$9.35
RB-140 #8 Large Soft Fan.....	\$9.90
RB-144 #4 Soft Fan.....	\$8.00

BAMBOO BRUSHES (Japanese)

Each brush head mounted in a plastic holder for long life. A very economical brush.

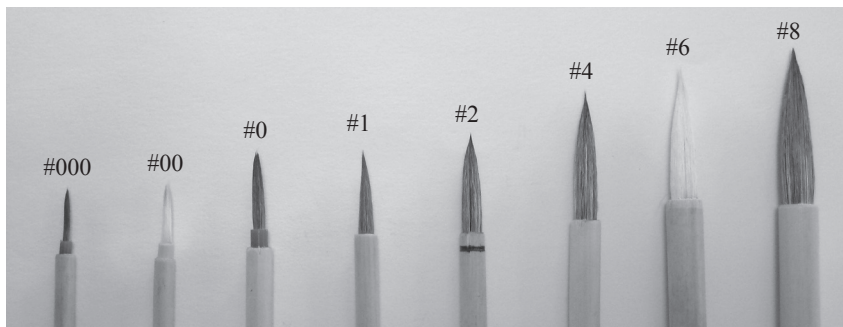

#000 Brush Small Detail.....	\$3.30
#00 Brush Small Detail.....	\$3.30
#0 Brush Small Detail.....	\$3.30
#1 Brush Medium Liner.....	\$3.30
#2 Brush Medium Liner.....	\$4.00
#4 Brush Medium Liner.....	\$4.40
#6 Brush Large Glaze.....	\$4.95
#8 Brush Large Glaze.....	\$6.00

HAKE BRUSHES

Soft sheephair flat chisel brush with wooden handle and stitched ferrule end. Ideal for covering large areas. Overall length 9 inches.



Small 1-1/8 inch.....	\$8.80
Medium 2 inch.....	\$11.00
Large 3 inch.....	\$15.50
Jumbo 4-1/2 inch.....	\$21.00

New: Bamboo Combination Brush.....\$7.05
12 individual snap off brushes, 3 3/4" wide
(See website for picture)

Sponges

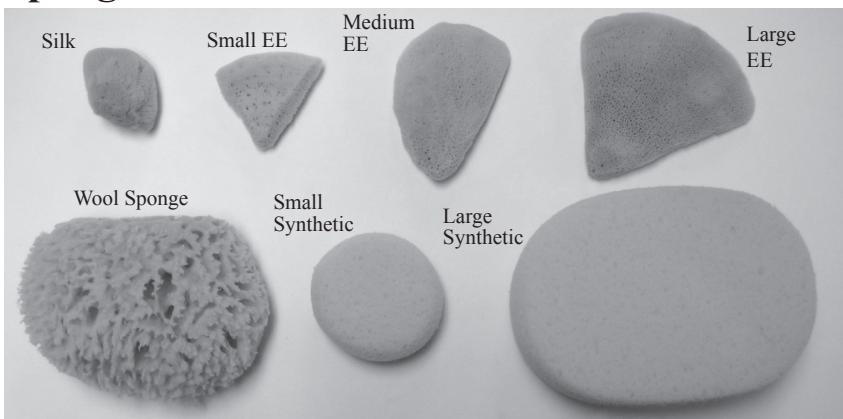

Silk Sponges.....	\$2.00
Small Round Synthetic.....	\$1.25
Mediterranean Wool Sponges, large.....	\$11.00
Large synthetic Oval Sponges.....	\$3.30
Elephant Ear Sponges:	
Small 2-3".....	\$3.00
Medium 3-4".....	\$4.95
Large 4-5".....	\$7.70

Skutt High Temperature Electric Kilns

Kilns 38



SKUTT
CERAMIC PRODUCTS



Standard Features

- UL and CSA listed.
- 2 year limited warranty.
- 12-side design eliminates hot spots. (some models)
- Stainless steel jacket.
- 3-heat switching.
- Available in 208 or 240 volt, 3 phase or single phase.
- Full trough groove with exposed, pinned elements for excellent heat distribution.
- 3" wall bricks for better heat retention. (some models)
- Sectionalized construction for easy brick and element replacement.
- 2 lift handles on each section for easy stacking.
- Sealed, dust-free lid with full floating hinge.
- Dawson Kiln-Sitter and Limit Timer.
- Air cooled switch box, louvered to keep out dust.
- Reversible top and bottom slabs in case of damage.
- Out of the way, side-mounted control box.
- Fully assembled stand included, with no-mar footpads.
- Lid Lifter standard on all 10 and 12 sided kilns.

Optional Accessories

- 4-1/2" Blank Ring
- Pyrometer

SKUTT KILN SITTER

Skutt Model KM1027 7.0 cu. ft.

THE ENERGY SAVERS

Skutt offers a 20% advantage. Now they offer the popular 8 and 10 sided kilns with 3" firebrick. That's 20% thicker than standard 2-1/2" brick. Their better insulating properties mean faster heat build-up and more even heat distribution from top to bottom. Depending on your electric power rates and whether you fire indoors or outdoors, the savings can be significant.

All Skutt energy saving kilns come with built-in Dawson Kiln-Sitter standard. Limit Timer and Pyrometers are optional. And unlike some 3" competitive models that require costly direct wiring, all Skutt energy efficient kilns plug into a standard 6-50 wall socket. In addition to all this, you get one of the best warranties in the business. Skutt Ceramic Products has stood behind its products for over 40 years.

NEW — All kilns marked with an * now come with the new Skutt Lid Lifter. Makes the lids light and easy to lift and open.

Model	Cone/Temp.F.	Internal Dim.	Cu. Ft.	Amps/Volts	Ship. Wt.	C.C.C. Price
KS-1227-3	8/2300	28.12 x 27	9.9	48/230 V	400	*\$3365.00
KS-1027	10/2350	23.38 x 27	7.0	48/230 V	290	*\$2845.00
KS-1027-3	10/2350	22.38 x 27	6.4	48/230 V	320	*\$2920.00
KS-1018	10/2300	23.38 x 18	4.0	38.5/230 V	250	*\$2255.00
KS-1018-3	10/2300	22.38 x 18	4.2	38.5/230 V	275	*\$2355.00
KS-818	10/2350	17.5 x 18	2.6	26.7/230 V	145	\$1510.00
KS-818-3	10/2350	16.5 x 18	2.3	26.7/230 V	160	\$1580.00
KS-714	8/2300	14.38 x 13.5	1.3	20/110 V	95	\$1305.00
Skutt Hi Temp. Digital Pyrometer						\$125.00
Dawson Kiln Sitter						Standard
Limit Safety Timer						\$100.00

Prices shown indicate 240V, single phase. Additional charge for 3 phase wiring.

Not applicable to KS 1018, 818, 714, single phase only.

39 Kilns

SKUTT KILN MASTER

Model	Volt	Maximum Cone	Temp	Cu. Ft.	Amps	Shipping Weight	C.C.C. Price
KM-818	240	10	2350	2.6	27.8	145	\$1740.00
	208	10	2350	2.6	26.7	145	1740.00
KM-1018-3"	240	10	2350	4.4	39.4	275	*\$2470.00
	208	10	2350	4.4	40.0	275	*2470.00
KM-1018	240	10	2350	4.7	39.4	250	*\$2370.00
	208	10	2350	4.7	40.0	250	*2370.00
KM-1027-3"	240	10	2350	6.6	48.0	320	*\$302000
	208	10	2350	6.6	48.0	320	*3020.00
3-phase	240	10	2350	6.6	29.3	320	*3070.00
	208	10	2350	6.6	31.7	320	*3070.00
KM-1027	240	10	2350	7.0	48.0	290	*\$2935.00
	208	6	2250	7.0	48.0	290	*2935.00
3-phase	240	10	2350	7.0	29.3	290	*2985.00
	208	10	2350	7.0	29.5	290	*2985.00
KM-1218-3"	240	10	2350	6.6	48.0	330	*\$2935.00
	208	10	2350	6.6	48.0	330	*2935.00
3-phase	240	10	2350	6.6	29.3	330	*2985.00
	208	10	2350	6.6	31.7	330	*2985.00
KM-1227-3"	240	8	2300	9.9	48.0	400	*\$347500
	208	5	2185	9.9	48.0	400	*3475.00
3-phase	240	8	2300	9.9	29.3	400	*3525.00
	208	8	2300	9.9	31.7	400	*3525.00
KM-1231 (3 pk.)	240	10	2350	11.6	72.0	450	*\$4220.00
	208	10	2350	11.6	80.0	450	*4220.00
3-phase	240	10	2350	11.6	44.5	450	*4220.00
	208	10	2350	11.6	51.5	450	*4220.00
KM-1627 (3 Pk.) Oval 3-phase only	240	10	2350	18.5	66.0	535	\$6750.00
	208	10	2350	18.5	76.0	535	6750.00
KM-16F Front Loader	240/208	10	2350	11.5		1100	\$11,499
KM-1 Wall mounted Controller 208-240V 50 Amp							\$930.00
KM-1 Wall mounted Controller 208-240V 3 phase 40 Amp							985.00
Zone Control available on select kilns							300.00
Skutt Enviro Vent 2							505.00

Freight F.O.B. Portland, OR

22" KM Series ~ More Room ... Easier to Load

Model	Phase	Volts	Amps	Watts	Cone	Temp	Cu. Ft.	Opening	Depth	Ship Wt.	Copper Wire Size	Breaker Size	NEMA Receptacle	Price
KM822	1	240	33.4	8000	10	2350	3.2	17.5	22	165	8	50	6-50	\$1865.00
KM822	1	208	38.5	8000	10	2350	3.2	17.5	22	165	8	50	6-50	1865.00
KM822-3"	1	240	33.4	800	10	2350	2.9	16.5	22	180	8	50	6-50	1930.00
KM822-3"	1	208	38.5	800	10	2350	2.9	16.5	22	180	8	50	6-50	1930.00
KM1022	1	240	48	11500	10	2350	5.7	23.5	22	270	6	60	6-50	2650.00
KM1022	1	208	48	9984	10	2350	5.7	23.5	22	270	6	60	6-50	2650.00
KM1022	3	240	34.6	11500	10	2350	5.7	23.5	22	270	8	50	15-50	2700.00
KM1022	3	208	34.6	11500	10	2350	5.7	23.5	22	270	8	60	15-50	2700.00
KM1022-3"	1	240	48	11500	10	2350	5.25	22.5	22	300	6	60	6-50	2745.00
KM1022-3"	1	208	48	9984	10	2350	5.25	22.5	22	300	6	60	6-50	2745.00
KM1022-3"	3	240	34.6	11500	10	2350	5.25	22.5	22	300	8	50	15-50	2795.00
KM1022-3"	3	208	34.6	11500	10	2350	5.25	22.5	22	300	8	50	15-50	2795.00

SKUTT GLASS MASTER

Kilns 40



GM 818

Skutt Glass Kilns

The Skutt Glass Master Kilns are perfect for fusing, slumping, bead making and annealing large glass sculptures. Each Skutt glass kiln is equipped with the Glass Master controller. This controller is easy to program and offers the artist an array of innovative features. The Clamshell kiln's (GM-22CS) unique design is perfect for the professional studio artist. For beginning glass fusers and glass jewelry makers Skutt offers smaller glass kilns available in 115 volt for household use.



GM 1414 Studio Series

Model	Temp.F.	Internal Dim.	Cu. Ft.	Amps/Volts	Ship. Wt.	C.C.C. Price
GM-814	1800	17.5 x 13.5	2	27/240 V	130	\$1650.00
GM-1014	1800	23.5 x 13.5	3.3	34/240 V	174	1890.00
GM-1214-3	1800	28 x 13.5	5	42/240 V	275	2675.00
GM-1414	1800	41.5 x 24.5 x 13.5	6.7	40/208 V	305	3095.00
GM-818	1800	17.5 x 18	2.6	27.8/240 V	147	1790.00
GM-1018	1800	23.5 x 18	4.6	39.4/240 V	196	2170.00
GM-1227-3	1800	28 x 27	4.6	48/240 V	351	3545.00
GM-22CS	1800	23.25 x 24.5 x 13.5	4.35	31/240 V	247	3175.00
GM-10F	1800	10 x 9 x 9	.45	15/115 V	82	1135.00
Hot Start Pro	1700	15 x 6.5	.6	15/115 V	100	1020.00
GP-706	1650	15 x 6.5	.6	15/115 V	66	840.00
Fire Box 8	2000	8 x 8 x 4.5	.17	15/115 V	45	535.00

Freight F.O.B. Portland, OR

Skutt Enviro Vent 2

The EnviroVent 2 is a Downdraft Ventilation System designed to extract fumes from your electric kiln and vent them outdoors before they have a chance to enter the room. Because it is a Down-Draft Ventilation System the EnviroVent 2 also improves the firing atmosphere in the kiln while it is protecting you from the odorous fumes that can be emitted from certain clay bodies and glazes when they are fired.



Call us toll free 1.866.410.CLAY

-Vent 2 kilns or large ovals with 1 motor.

-Spring loaded plenum cup assures a tight, leak-free seal throughout the firing process.

-Negative pressure means no leaking.

- Ability to program on/off with Skutt controller.

-U.L. Listed venting system with Skutt kilns.

-Only U.L. Listed venting system with Skutt Kilns.

-Optional floor mount kit and 4" adapter included free.

-Remote mounting equals no vibration and longer motor life.

Enviro Vent 2.....\$505.00

Dual intake kit.....\$155.00

8' extension kit.....\$32.00

Enviro Link.....\$115.00

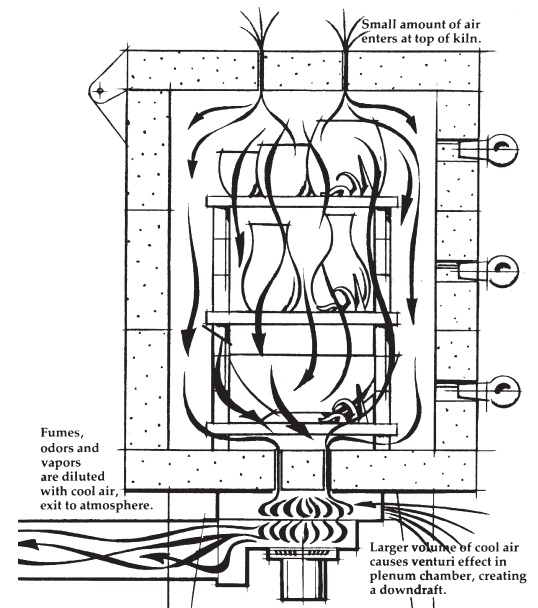

Serving Schools and Studios Since 1939

41 Kilns

Model No.	Description	Price
ELEMENTS		
All elements are pre-formed and are accompanied by connectors and instructions. Be SURE to state model number and voltage!		
714,145	Element/240-208V	\$41.00
181,181-27, 180	Element/240-208V	41.00
183, 183-27, 818P	Element/240V	41.00
185, 185-27, 818	Element/240V	41.00
1027, 231, 235	T&B Element/240V	53.00
1027, 231, 235	Center Element/240V	53.00
1027, 231, 235, 1PH & 3 PH	1PH & 3 PH Top & Btm Elem/208V	53.00
1027, 231, 235	Center Element/208V	53.00
1027, 231, 235, 3PH only	3PH Center Element/208V	53.00
1018, 231-18	Top & Bottom Element/240V	53.00
1018, 231-18	Center Element/240V	53.00
1227-3	T&B Element/240-208V	53.00
1227-3	Center Element/240-208V	53.00
ELECTRICAL ACCESSORIES		
	Analog Pyrometer (Meter Only)	\$120.00
	Analog Pyrometer w/Thermocouple	150.00
	Digital Pyrometer w/Thermocouple	125.00
	Thermocouple Replacement	42.00
609, 614-3 & 12F	120V Infinite Switch	37.00
	240V Infinite Switch Package	37.00
	3 Heat Switch Pkg.	83.00
	3 Heat Knob	8.00
	Infinite Switch Knob	8.00
	Feeder Wires/Infinite Switch	12.00
	Feeder Wire for 3 Heat Switch	15.00
	Pilot Lite/240V	15.00
Per Foot	14 Ga Awg Nickel Wire	5.25
KM	Thermocouple Replacement	18.00
KM	Relay 25A	31.00
KM	Harness Wire Set	33.00
CORDS & PLUGS		
714, 145, 181	Power Cord Set	\$60.00
818, 1018, 183, 185, 231-18	Power Cord Set	55.00
1027, 1027-3, 1227-3,	Power Cord Set	90.00
	Plug (1 PH)	50.00
	Plug (3 PH)	65.00

Must Specify Manual or Automatic Kiln

ALL SKUTT PARTS/AUTOMATIC & MANUAL AVAILABLE UPON REQUEST
CALL FOR CURRENT INFO & PRICING

SKUTT REPAIR PARTS

Model No.	Description	Price
BRICKS		
All Models (Please Specify)		\$12.50
LID HARDWARE AND REPLACEMENT PACKAGES		
818, 614, 714	Lid Brace Package (State Model)	\$18.00
1018, 1027 & 1227-3	Lid Brace Package (State Model)	41.00
All Models	Anchor Pads	6.00
All Models	Lid Lifter Kit	310.00
All Models	Lid Latch/Prop Kit	20.00
LIDS & SLABS		
714,145	Lid	\$135.00
714,145	Slab	130.00
818, 818P, 181	Lid	155.00
818, 818P, 181	Slab	145.00
1027, 1018, 231-18, 231	Lid	200.00
1027, 1018, 231-18, 231	Slab	185.00
1027-3, 1018-3	Lid	230.00
1027-3, 1018-3	Slab	215.00
All of above lids and slabs can be shipped via UPS.		
1227-3,280	Lid	290.00
1227-3,280	Slab	265.00
	Lid or Slab Crate Charge	35.00
KILN SITTER		
145, 181, 231-18	Shut Off Tube Assembly	\$46.00
609, 818, 818P, 1018, 1027	7.0" Shut Off Tube Assembly	46.00
1227-3 & All 3" Models	X-Long Shut Off Tube Assembly	46.00
145,181, 231-18, 231	K-S Short Sensing Rod	9.00
609, 714, 818, 818P	7.0" Sensing Rod	9.00
1018, 1027		
1227-3 & All 3" Models	X-Long Sensing Rod	9.00
All New Models	Guide Plate w/Claw	16.00
Old Model Numbers	Dawson Pinned Claw	14.00
All Models	Pair Kiln-Sitter Cone Rests	9.00
All Models	K-S Gauge Washer	5.00
	K-S Switch Block w/Cont & Plngr	70.00
	Dawson Model LT-3K Faceplate	160.00
609, 614-3	Dawson Model K Faceplate	140.00
	Timer Motor Only	60.00
State Model #	KS Lock Spring	7.00

Kiln Safety Screen

Designed to keep kiln area clear and protect students and employees from possible injury when kiln is in operation. To create a highly visible warning, the screen is imprinted with the words "CAUTION KILN IN OPERATION" in yellow print.

Made with fire retardant canvas curtains and sturdy aluminum tubing frames, each panel measures 2' x 3'. Three panels are included in a set. Additional panels may be purchased to cover larger areas. Shipped unassembled, all necessary parts are included for assembly.

Cat. No.	Description	Price
VAK11-KS3	Kiln Safety Screen — 3 panel set	\$156.00
VAK11-KS1	Extra Screen Panels with clips, each	55.00

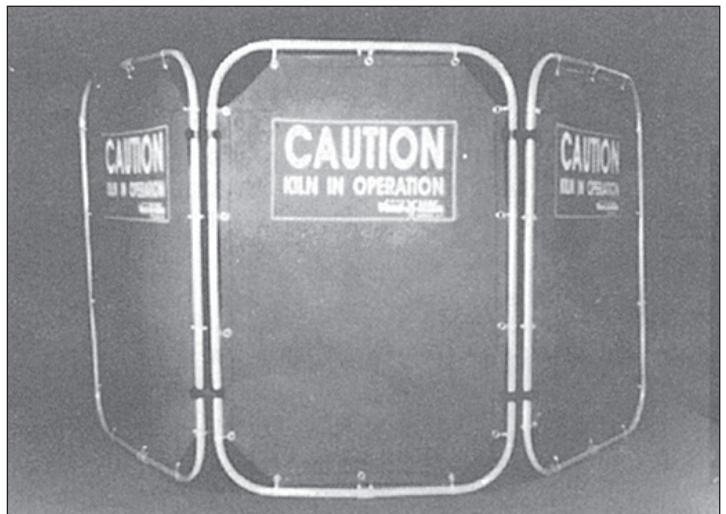



Orton Vent Master®

All products fired in electric kilns contain organic materials that make carbon monoxide and other fumes when they are burned. Fumes released may contain sulfur oxides, hydrogen fluoride and metal vapors, depending on the products fired. Carbon monoxide and other fumes can affect the color and properties of the fired product if they are not removed from the kiln earlier in the firing. Red, green, gold and similar products are particularly affected by carbon monoxide at temperatures where the color develops.

The Vent Master motor / blower is built from a non-corrosive, lightweight plastic that allows you keep it on the floor, or mount VentMaster to the wall. VentMaster does not transfer any vibration to your kiln, is capable of venting two kilns at once and is easy to install! Fits all kilns. ETL/CE Certified.

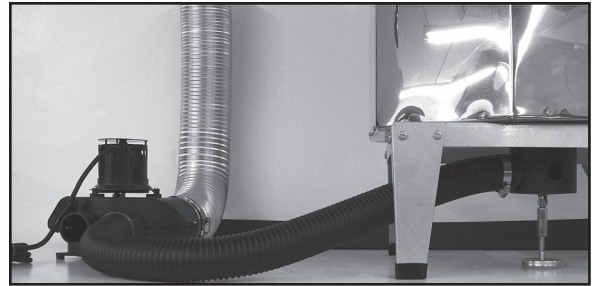

Orton Vent Master®
F.O.B. Columbus, OH

C.C.C. Price
\$495.00

Vent-A-Kiln

- Easy installation.
- Two-speed exhaust control UL & CSA listed.
- Spun aluminum hood compactly designed to fit easily on top of closed or vented kiln.
- Complete with outside venting kit and overhead counterweight pulley system.
- Less than one cent per hour to operate under average conditions.
- 3 year warranty

Vents unwanted, unhealthy fumes.

When firing glazes, toxic fumes are frequently liberated as well as unpleasant odors from decals, lustres and gold. Vent-A-Kiln controls those fumes preventing contamination of the air in the kiln area.

Eliminates excess heat.

Enjoy more comfortable working conditions! Hot stifling air is swiftly drawn outdoors by Vent-A-Kiln, dramatically increasing workroom comfort.

Reduces air-conditioning cost.

As hot kiln air is immediately drawn outdoors, summer working temperatures are remarkably lowered. Therefore, expensive air conditioning may not be needed in some workrooms, while equipment operating costs can be sharply reduced in others.

Portability.

Vent-A-Kiln is light and compact and may be moved from one kiln to another if desired.

Includes:

Fan motor (115V.) with on & off switch and plug, hood, convenient overhead counterweight pulley system, venting kit with 10' of 4" hose, all clamps, and external mounting plate for discharge.

Vent-A-Kiln Specifications

Model No.	A Hood Dia.	B Hood Depth	Fits Round Kiln*	Fits Rect-angular*	Ship. Wt.
1122	22"	4"	16-20"	16-22"	28 lb.
1227	27"	5"	21-25"	23-27"	30 lb.
1332	32"	6"	26-30"	28-32"	32 lb.
1437	37"	7-1/4"	31-37"	33-37"	34 lb.
1544	44"	8"	38-44"	38-44"	36 lb.

*Outside kiln dimensions.

Vent-A-Kiln Prices F.O.B. Buffalo, NY

Model Number	C.C.C. Price
1122.....	\$479.00
1227.....	499.00
1332.....	599.00
1437.....	639.00
1544.....	699.00
1654.....	959.00
11-47 Swinging wall bracket (22", 27", 32", 37").....	68.00
11-44 Swinging wall bracket (44" hood).....	116.00
11-54 Swinging wall bracket (54" hood).....	147.00

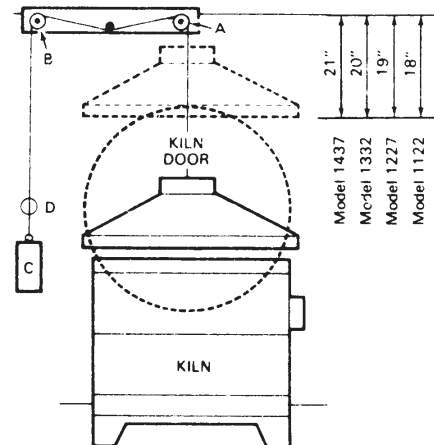

43 Kilns

Vulcan Kilns



265 G oval with kiln sitter & LT3 timer

Vulcan Kilns is a family-owned kiln manufacturer located in Dayton, Ohio since 1958. Vulcan offers a full line to meet your needs including kilns designed for Ceramics, Pottery, China, Porcelain, Jewelry, PMC Metal as well as Test Ovens for manufacturing applications. Vulcan Kilns are engineered to be the highest quality kiln on the market.

- * Solid one-piece construction-will not loosen up
- * 2 Year Warranty
- * Full stainless steel jacket, including bottom
- * Sturdy brick design
- * High quality materials
- * Built to last for many years
- * Orton Auto Fire computer controller on all automatic kilns, AF3 or AF 3000

Vulcan Kilns can also custom design a kiln for your specific application.

Model	Cone Temp. F	Internal Dimensions	Cu. Ft.	Amp	Manual Price	Auto Fire Price
JK-1 Test Kiln W/Pyro.	6/2250	6" w x 6" d x 4 1/2" h	.1	10/115v	\$350	\$640 AF3
JK-X Deluxe Test Kiln	6/2250	6" w x 6" d x 6 1/2" h	.135	10/115v	\$400	\$700 AF3
111F W/Pyro	6/2250	11" w x 4 1/2" h	.31	14/115v	\$480	\$725 AF3
112 F Counter top Kiln	9/2300	11" w x 9" h	.57	18/115v	\$730	\$870 AF3
172 Oval small Kiln	6/2050	17" w x 11" d x 11" h	1.0	18/115v	\$840	\$970 AF3
172 Oval small Kiln	9/2300	17" w x 11" d x 11" h	1.0	12/230v	\$840	\$970 AF3
174 F Kiln	9/2300	17 3/8" w x 18" h	2.6	22/230v	\$1120	\$1350 AF3000
175 F Kiln	9/2300	17 3/8" w x 22 1/2" h	3.25	26/230v	\$1350	\$1550 AF3000
216 F Kiln	9/2300	21" w x 27" h	5.2	30/230v	\$1700	\$2000 AF3000
246 F Kiln	9/2300	23 3/8" w x 27" h	7.0	45/230v	\$2000	\$2300 AF3000
265 G oval Kiln	9/2300	26 1/2" w x 17" d x 22 1/2" h	5.25	40/230v	\$1700	\$2300 AF3000
336 G oval Kiln	9/2300	33 1/2" w x 23" d x 27" h	10.20	48/230v	\$2500	\$2900 AF3000
417 G large oval Kiln	9/2300	41" w x 25" d x 27" h	13.8	67/230v	\$3450	\$3900 AF3000

NOTE: All manual kilns include a LT3 safety timer, EXCEPT the JK-1 test kiln and 111F which include analog pyrometer. Price are for pick up at Columbus Clay ONLY. Extra charges apply for shipping kilns, please call for more information.

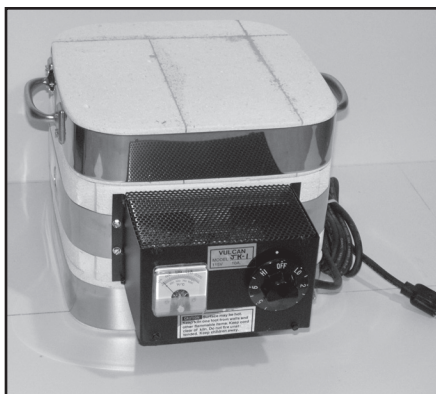

JK-1 with Pyrometer

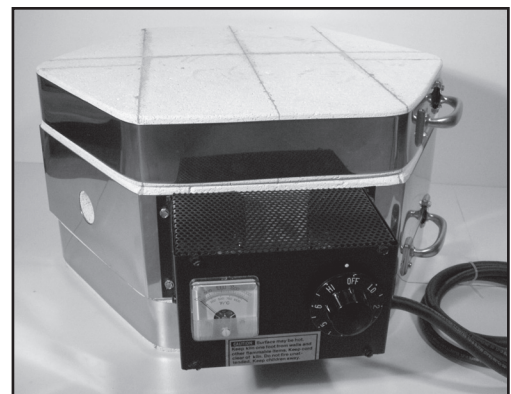

111 F with Pyrometer

Olympic Gas Kilns

Olympic has incorporated very high quality standards into their line of "Torchbearer Gas Kilns". Portable gas kilns offer many advantages such as low initial cost, convenient movement for demonstration firings, and for use in situation where space does not permit the installation of large permanent kilns. The Olympic "Torchbearer Kilns" will fire to cone 10 using natural gas or propane. You can fire these kilns in oxidation, reduction or raku firing. The multiple burner configuration gives the kilns very even heating characteristics, fast controllable firing times and economical operation. We have 3 "Torchbearer Kilns" sizes available and 3 RAKU Kilns. See the table below for sizes and prices.

Model	Dimensions	Cu. Ft.	Call For Pricing
1827G	17 1/2 x 27 deep	3.95	
2327G	23 2/8 x 27 deep	7.00	
2827G	28 1/4 x 27 deep	10.00	
18 RAKU	17 1/2 x 22 deep	3.29	
23 RAKU	23 3/8 x 27 deep	7.00	
28 RAKU	28 1/4 x 27 deep	10.00	

Ignition ring and thermal shut off
 K.S. relay system
 Plus freight F.O.B. Atlanta Georgia



2327 G

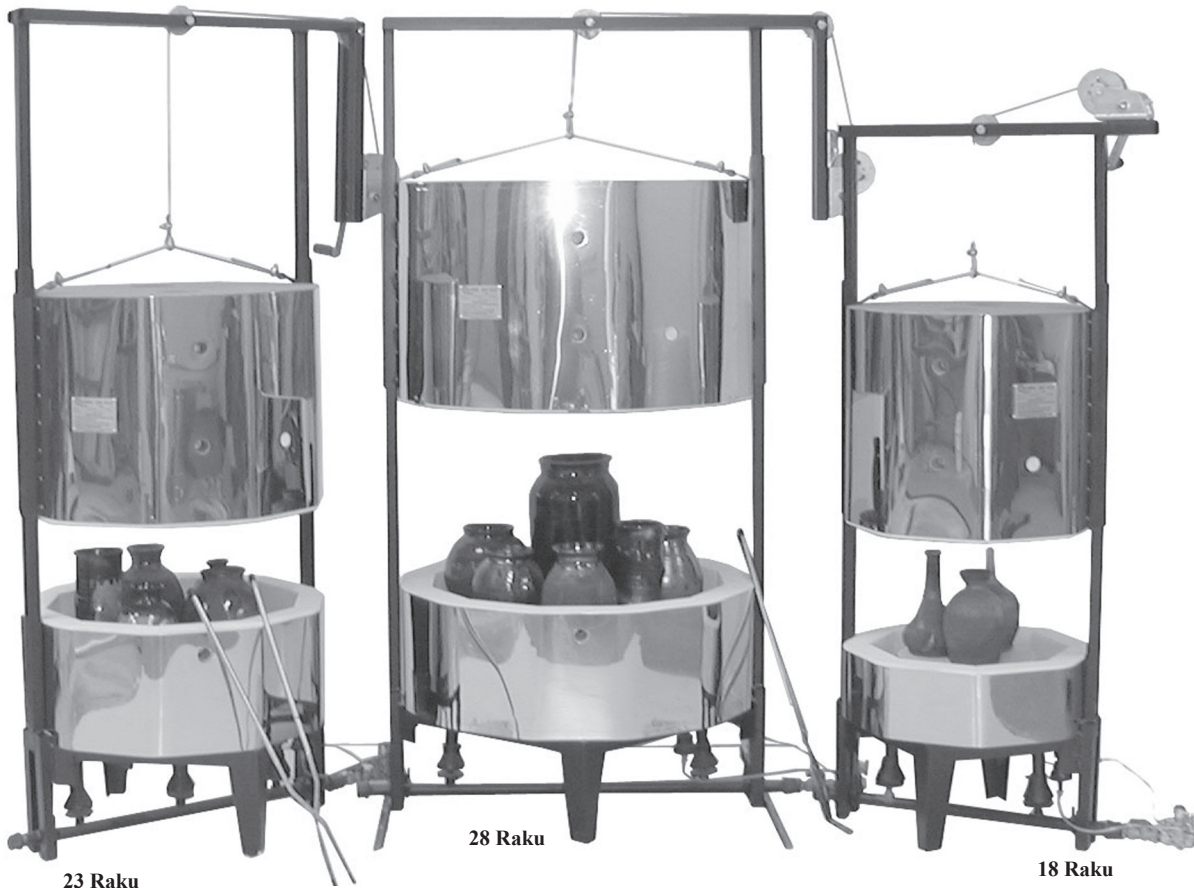

23 Raku

28 Raku

18 Raku

Columbus Clay carries a line of raku glazes pg. 24, raku tongs pg. 33, and raku gloves pg. 45

45 Kilns

Kiln Shelves and Posts

Diameter	Thickness	Shape	Price
14 Inch Diameter Kilns			
13-1/2	5/8"	round/full	\$26.00
13-1/2	5/8"	round/half	14.00
18 Inch Diameter Kilns			
15-1/2	5/8"	round/full	\$32.00
15-1/2	5/8"	round/half	17.00
20 Inch Diameter Kilns			
19	3/4"	round/full	\$52.00
19	3/4"	round/half	27.00
24 Inch Diameter Kilns			
21	5/8"	round/full	\$54.00
21	5/8"	round/half	29.00
29 Inch Diameter Kilns			
26	5/8"	round/half	\$42.00
26	1"	round/full	67.00

Other Shelves	Thickness	Shape	Price
4-1/2 x 4-1/2	1/2"	square	\$10.00
26 x 14	5/8"	rectangular	60.00
21 x 15	3/4"	rectangular	70.00
12 x 24	1/2"	rectangular	40.00
12 x 24	1"	rectangular	55.00

Custom Shelves

As a service to our customers we also custom cut shelves to your dimensions. For pricing information contact us.

All shelves are made of cordierite.

Posts: 1-1/4" I.D. by 2" O.D. (Round shelf supports)

Height	Price	Height	Price
1"	\$1.60	8"	\$2.45
2"	\$1.85	10"	\$2.70
3"	\$2.10	12"	\$3.50
4"	\$2.20	14"	\$4.10
6"	\$2.30		

Kiln Furniture Kits

Catalog #	Kiln Model	Description	Regular List Price	OUR PRICE
CCKIT #1	Skutt 1227-3 Aim 2927 Olympic #2827, 2831	Shelves: 8 half shelves 26" wide Posts 6 each of: 3, 4, 6, 8, 10, 12 inch 2 lb. of kiln wash	\$605.00	\$399.00
CCKIT #2	Skutt 1027, 1027-3 Aim 2327, Vulcan 246 Olympic #1827	Shelves: 2 full 21" diameter, 4 half 21" diameter Posts: 6 each of 2, 4, 6, 8, 10, 12 inch 2 lb. of kiln wash	\$375.00	\$308.00
CCKIT #3	Skutt 1018 Olympic #1818, #1823	Shelves: 1 full 21" diameter, 4 half 21" diameter Posts: 6 each of 2, 4, 6, 8 inch 1 lb. kiln wash	\$308.00	\$220.00
CCKIT #4	Skutt 818 Vulcan 174F Olympic S18A, S1823A	Shelves: 2 full hex shelves, 15-1/2" wide; 3 half hex shelves, 15-1/2" wide Posts: 3 each of 1, 2, 3, 4, 6, 8 inch 1 lb. kiln wash	\$187.00	\$149.00

Kiln Accessories

Sairset Hi-temp. Repair Kiln Cement	\$5.45/lb.	Kiln wash	See Page 8
Kiln Safety glasses	\$14.25/pr	Cone holders CHJ (small)	\$3.75
Skutt Hi-Temp. pyrometer digital with thermocouple	\$132.00/ea.	Cone holders CHS (large)	\$4.40
Separate thermocouple only	\$54.00/ea.	Element Pins (pkg of 12)	\$4.10
CCC thermocouple (type K)	only \$31.00/ea.	Element Staples (pkg of 12)	\$4.65
Kiln peep hole plugs (hollow cast)	\$5.45/ea.	Raku gloves (Kevlar)	\$60.00/pr.
Insulating fiber blanket 1" thick	\$6.60/sq. ft.	Raku gloves (leather)	\$19.95/pr.
		Soft Firebrick (ungrooved)	
		9" x 4 1/2" x 2 1/2"	\$7.50
		9" x 4 1/2" x 3"	\$9.00

Kilns 46

Stilts

Item	# Pins	Diameter/Length	Price
1	3	.5 inch	\$.85
2	3	1.0 inch	.95
3	3	1.5 inch	1.10
4	3	2.25 inch	1.40
5	12	2.25 inch	1.90
6	12	3.65 inch	2.75
7	3	3.65 inch	1.85
8	12	5.50 inch	5.50
9	9	7.50 inch	5.00
10	11	3.00 inch	2.75
11	15	4.00 inch	3.10

These stilts are rated to cone 11, however we recommend stilt-ing for cone 06-04 firings.

Refractories

Tile Setters for 6x6.....	\$32.00
Tile Setters for 4x4.....	32.00
Plate Setter 10-1/2x12x2-1/2.....	14.50
All Ceramic Stilt Assortment (100).....	33.00
NEW Bead Post Set w/6,6" Rods.....	24.00

High Temperature Wire

Special high-temperature alloy wire can be used for any project that requires wire support in high temperatures of ceramic kilns; bottle sagging, bead supports, special stilts, element pins, kiln furniture, cone holders.

12" Rods 1/8 Diameter	\$7.75
36" Rods .085 Diameter	11.00
10' Coil 17 Gauge.....	6.75

Element Pins and Staples

Sharp-ended for easy insertion in the kiln wall, these devices hold loose kiln elements in place. Made of a high temperature resistant alloy for temperatures to 2500°F (Cone 13) Package 12 per package. 1 1/4" long

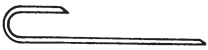
	
ELP Element Pins.....	\$3.59
	
ELS Element Staples.....	\$4.49

ORTON Pyrometric Cones

Pyrometric cones measure heat-work (the effect of time and temperature). Pyrometric cones are slender pyramids made from about 100 carefully controlled compositions. Each cone number is unique in measuring temperature within a small temperature range (less than 30°C). Cones measure the amount of heat absorbed. As the cone nears its maturing range, it softens and the tip begins to bend, drawn down by the influence of gravity. We Carry a large line of Orton Cones for all your firing needs.

Small Cones (SRB) 022 through cone 13	
Box of 50.....	\$9.35
Large Cones (LRB) 019 through cone 13	
Box of 50.....	\$12.99
4 hole cone plaque.....	\$1.00

Self Supporting Cones (04, 05, 06, 4, 5, 6)
 Box of 25.....\$12.99
NOTE: VERY IMPORTANT! Make sure you are ordering the right cones! Cone 6 is a higher temperature than cone 06. If you are not sure of which cone to use, please give us a call!

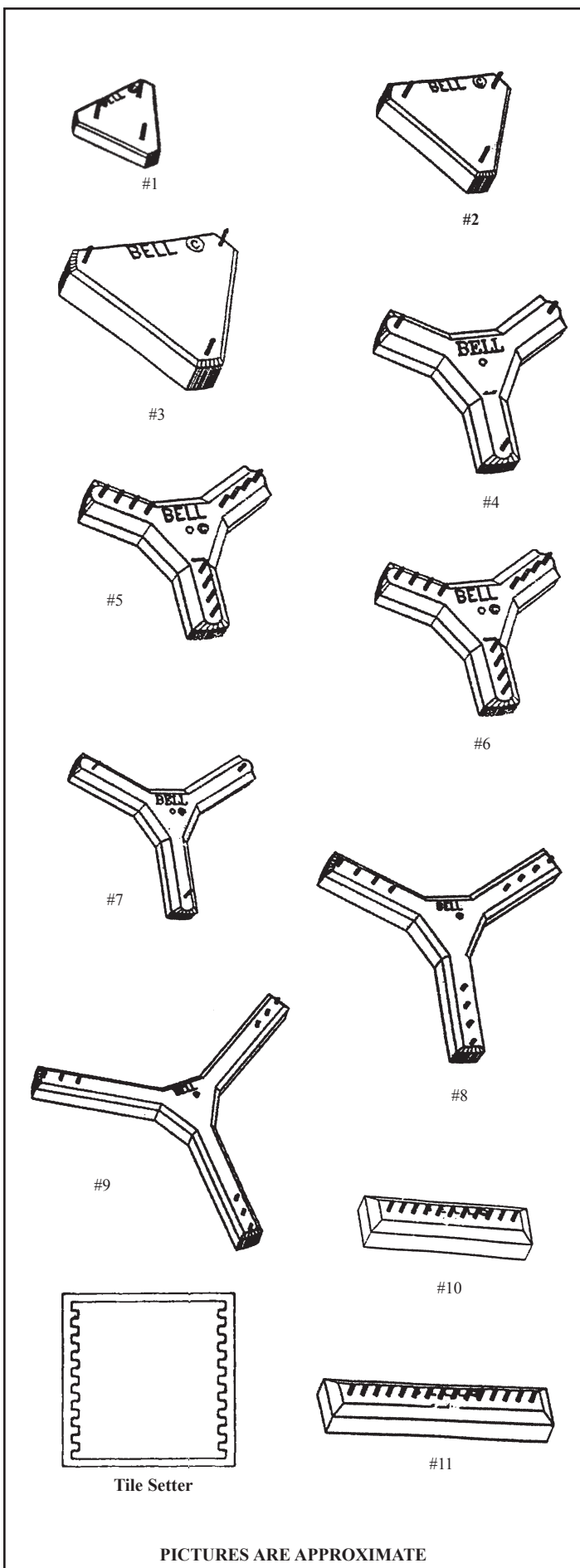

PICTURES ARE APPROXIMATE

47 Map

Columbus Ohio

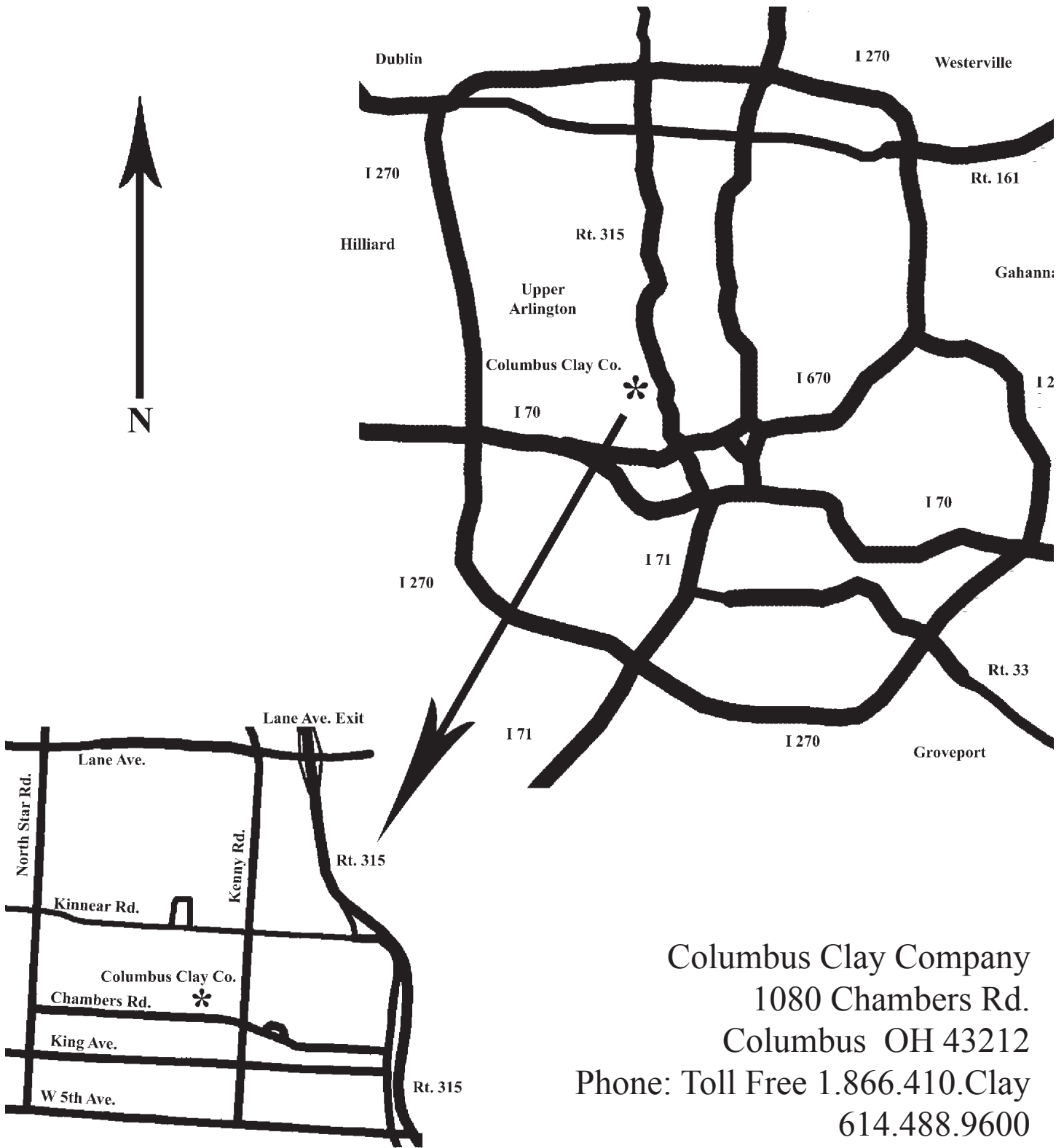

Columbus Clay Company
1080 Chambers Rd.
Columbus OH 43212
Phone: Toll Free 1.866.410.Clay
614.488.9600
Fax: 614.488.9849
Web: www.columbusclay.com